

# Data Sheet for Joysticks

Finger Joystick

Series 844



- Very robust joystick
  - Low installation depth of < 20 mm
  - Wide range of configurations/handles
  - Contact-less, wear-free Hall effect technology
  - Redundant Hall sensors (optional) for reliability
- Ideal for applications with high mechanical demands

The 844 series is the most rugged finger joystick in the range and is ideal for harsh conditions. The series uses modern Hall effect sensors and features robust mechanics (max. load 400 N) with up to 10 million life cycles. Special features include centre detect and centre tap outputs (not available on redundant versions). Many different handle styles are also available.

## Technical Data

Sensor technology	Hall effect
Supply Voltage $V_{\text{supply}}$	$5.0 \pm 0.5$ VDC ratiometric/transient free* or $3.3 \pm 0.1$ V (stabilized internally) CAN versions: 7 to 35 VDC
Voltage in Center Position*	$V_{\text{supply}}/2 \pm 2.5\%$ of Full Scale (F. S.) output
Output Impedance*	10 Ohm
Supply Current*	< 13 mA (2 axes) / < 20 mA (3 axes)
Impedance*	Min. 10 kOhm, > 100 kOhm recommended
Life Cycles	10 Mio. cycles (5 Mio. with 3 axes)
Output Signal*	0 to 5 V / 0.5 to 4.5 V / 0 to 3.3 V / 0.33 to 2.97 V (others on request)
Angle of Movement X-, Y-Axis / Z-Axis	$36^\circ (\pm 18^\circ \text{ from center}) / 50^\circ (\pm 25^\circ \text{ from center})$
Operating Force X-Y-Axis	Breakout force standard typ. 1.3 N (1.0 N and 1.6 N available on request)
Max. vertical Load to Mechanism	400 N
Operating / Storage Temperature	$-25^\circ\text{C}$ to $+70^\circ\text{C}$ / $-40^\circ\text{C}$ to $+70^\circ\text{C}$
Above Panel Sealing	Up to IP66 (depending on handle and sealing configuration)
EMC Emission	EN61000-6-3 CISPR 22:2005 Class B 30 MHz - 11 GHz
EMC Immunity	100 V/m 80 MHz - 2.7 GHz, 1 kHz 80% sine wave modul., EN61000-4-3 (extended)
ESD	EN61000-4-2 (extended) $\pm 8$ kV (20 contacts) & $\pm 15$ kV (20 air discharges)
Vibration	100 Hz - 200 Hz @ 0.13 $\text{g}^2/\text{Hz}$ , total 3.6 g RMS 1h in each of three perp. axes

\*Only for analogue and PWM versions

## Mechanism

The omni-directional metal mechanism features an extremely robust ball-socket pivot. This construction results in a product that is highly resistant to vertical impact and consistently withstand high pull, push, twist or horizontal forces.

## Magnetic screening

The 844 series incorporates internal magnetic screening to minimize the effect of external magnetic fields. However, we do not recommend mounting or operating the joystick near strong magnetic fields.

# Data Sheet for Joysticks

Finger Joystick

Series 844

Please contact us for information regarding stock articles, delivery times and minimum order quantities.

## Order Code

Description	Selection: <b>standard=black/bold</b> , possible <i>options=grey/italics</i>							
<b>Series</b>	<b>844</b>							
<b>Axes:</b> 1 Axis		1						
<b>2 Axes</b>		<b>2</b>						
3 Axes		3						
<b>Sealing/rubber boot:</b> <i>No bezel, below panel mounting</i>			1					
<b>Square bezel, drop-in mounting</b>			<b>2</b>					
<i>Circular bezel, below panel mounting</i>			3					
<i>Circular bezel, drop-in mounting</i>			4					
<i>Square bezel with wrap around rubber boot, drop-in mounting</i>			5					
<i>Circular bezel with wrap around rubber boot, drop-in mounting</i>			6					
<b>Return mechanism:</b> <b>Spring return</b>				1				
<i>Spring return with guided feel in X &amp; Y</i>				2				
<b>Handles:</b> <i>Handle A for 1-2 axes, no pushbutton, round, nylon</i>					A			
<i>Handle B for 1-2 axes, no pushbutton, cylindrical, anodized aluminium</i>					B			
<b>Handle C for 1-2 axes, no pushbutton, conical, nylon</b>					<b>C</b>			
<i>Handle E for 1-2 axes, with pushbutton, conical, anodized aluminium</i>					E			
<i>Handle F for 1-2 axes, no pushbutton, rubber boot protection, nylon</i>					F			
<i>Handle G for 1-2 axes, with 2 pushbuttons, large oval-shaped, nylon</i>					G			
<i>Handle H for 1-2 axes, with 1 pushbutton, large oval-shaped, nylon</i>					H			
<i>Handle I for 3 axes, no pushbutton, fluted, nylon</i>					I			
<i>Handle J for 3 axes, with 1 pushbutton, fluted, anodized aluminium</i>					J			
<b>Handle N for 1-2 axes, with 1 pushbutton, small, stainless steel/nylon</b>					<b>N</b>			
<i>Handle O for 1-2 axes, no pushbutton, concave top/low profile, nylon</i>					O			
<i>Handle P for 3 axes, with 2 pushbuttons, fluted, anodized aluminium</i>					P			
<i>Handle S for 3 axes, no pushbutton, soft touch, santoprene/nylon</i>					S			
<i>Handle T for 1-2 axes, with 1 pushbutton, tall ribbed, anodized aluminium</i>					T			
<i>Handle U for 1-2 axes, no pushbutton, tall ribbed, anodized aluminium</i>					U			
<i>Handle V for 1-2 axes, with 1 pushbutton, very tall fluted, anodized aluminium</i>					V			
<i>Handle W for 1-2 axes, with 2 pushbuttons, fluted, anodized aluminium</i>					W			
<b>Handle X for 1-2 axes, with 3 pushbuttons, nylon</b>					<b>X</b>			
<i>Handle Y for 3 axes, with deadman paddle, fluted, nylon</i>					Y			
<i>Handle Z for 3 axes, no pushbutton, fluted, anodized aluminium</i>					Z			
<i>Handle Q for 3 axes, no pushbutton, knurl, anodized aluminium</i>					Q			
<i>Handle QQ for 1-2 axes, no pushbutton, knurl, anodized aluminium</i>					QQ			
<b>Limiters:</b> <i>Circular</i>						5		
<b>Square</b>						<b>6</b>		
<i>Single Axis, Y direction only*</i>						2		
<i>X/Y Plus "+"</i>						3		
<i>Square rotated by 45°, "diamond"</i>						4		
<b>Sensor options:</b> <b>Standard analogue 5 V, (single)</b>							<b>S</b>	
<i>Dual redundant analogue 5 V, parallel output</i>							P	
<i>Dual redundant analogue 5 V, inverse/crossed output</i>							I	
<i>PWM</i>							W	
<i>CAN J1939</i>							7	
<i>CANopen</i>							8	
<i>Single analogue 3.3 V stabilized</i>							L	
<b>Output Signal:</b> <b>0 to 100% (0 to 5.0 V or 0 to 3.3 V)</b>								<b>5</b>
<i>10 to 90% (0.5 to 4.5 V or 0.33 to 2.97 V)</i>								4
<i>PWM/CAN</i>								-

\* Limiter in x direction is not available, because this function is achieved by installing joystick rotated by 90°

# Data Sheet for Joysticks

## Finger Joystick

Series 844

### Handle Types (Part 1)

All dimensions in mm (inches)

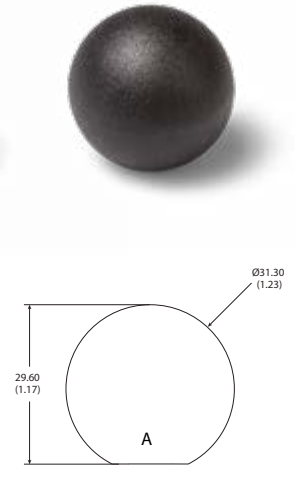
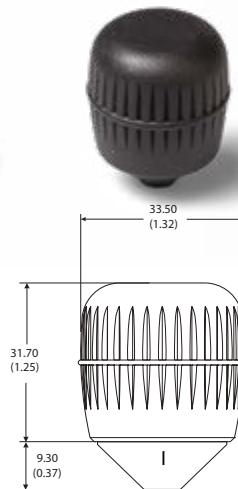
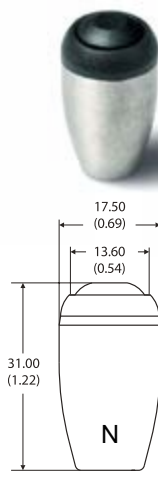
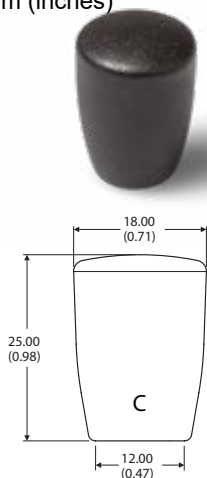

Handles	C	N	I	A
Material	Nylon	Aluminium	Nylon	Nylon
Finish	Sparked Matt	Natural	Sparked Matt	Sparked Matt
Standard colour	Black	Stainless steel/black	Black	Black
Notes	for 1-2 axes IP66 if sealing options 5 or 6 are selected	for 1-2 axes, with 1 Pushbutton	3rd axis functionality (rotation), IP66 if sealing options 5 or 6 are selected	for 1-2 axes

### Handle Types (Part 2)

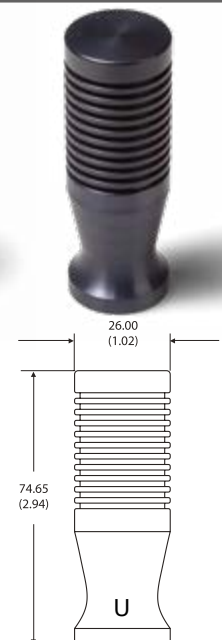
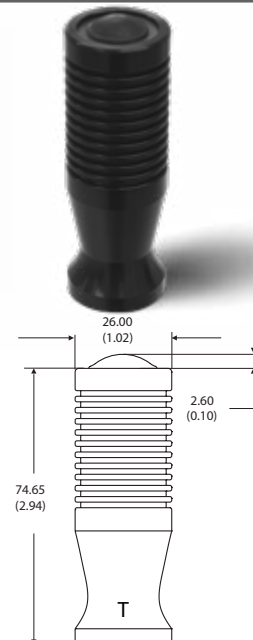
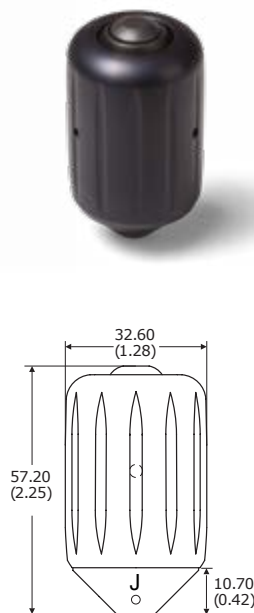
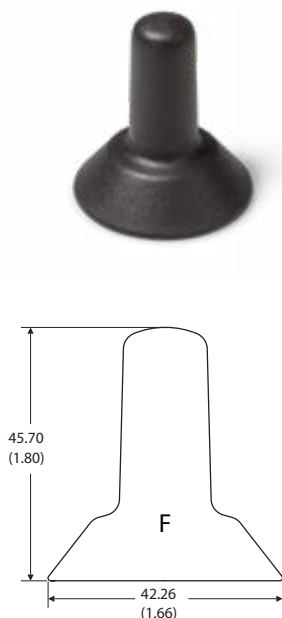

Handle Code	F	J	T	U
Material	Nylon	Aluminium	Aluminium	Aluminium
Finish	Sparked Matt	Anodized	Anodized	Anodized
Standard colour	Black	Black	Black	Black
Notes	for 1-2 axes IP66 if sealing options 5 or 6 are selected	3rd axis functionality (rotation), with Pushbutton	for 1-2 axes, with 1 Push- button, IP66 if sealing options 5 or 6 are selected	for 1-2 axes, IP66 if sealing options 5 or 6 are selected

Continued on next page

### Handle Types (Part 3)

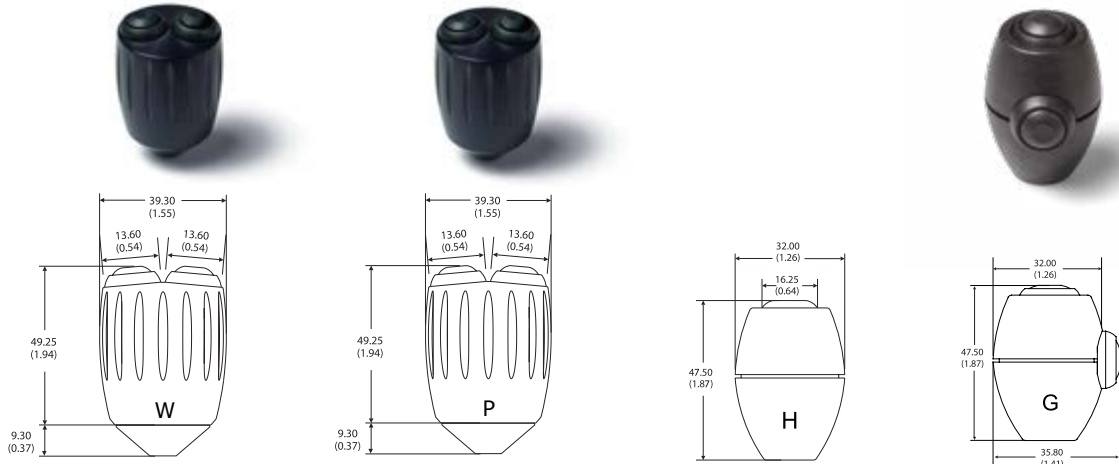

Handle Code	W	P	H	G
Material	Aluminium	Aluminium	Nylon	Nylon
Finish	Anodized	Anodized	Sparked Matt	Sparked Matt
Standard colour	Black	Black	Black	Black
Notes	for 1-2 Axes, with 2 Pushbuttons	3rd axis functionality (rotation), with 2 Pushbuttons	for 1-2 Axes, with 1 Pushbutton IP66 if sealing options 5 or 6 are selected	for 1-2 Axes, with 2 Pushbuttons

### Handle Types (Part 4)

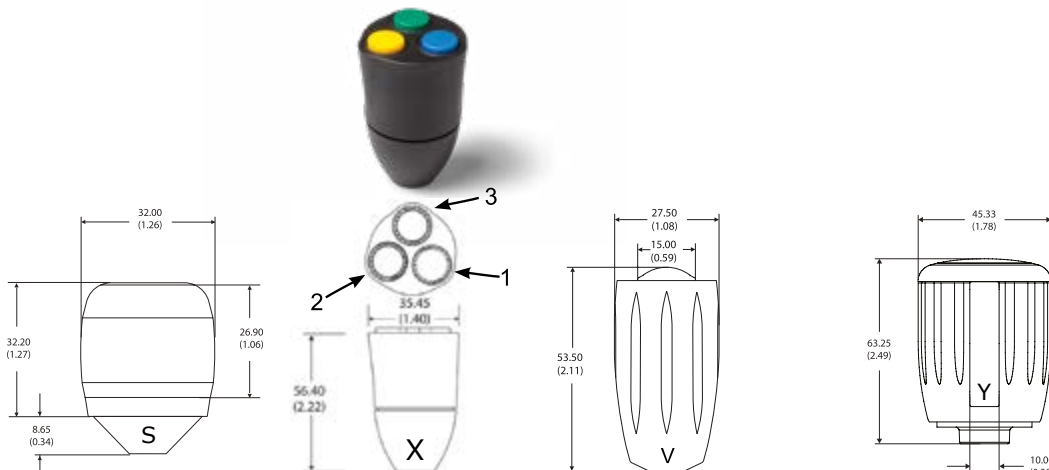

Handle Code	S	X	V	Y
Material	Santoprene / Nylon	Nylon	Aluminium	Black Mineral Filled Nylon
Finish	Soft Touch	Sparked Matt	Anodized	Light Sparked Finish
Standard colour	Black	Black	Black	Black
Notes	3rd axis functionality (rotation)	for 1-2 axes, with 3 Pushbuttons	for 1-2 axes, with 1 Pushbutton	3rd axis functionality (rotation), with 1 Deadman Switch

# Data Sheet for Joysticks

## Finger Joystick

Series 844

### Handle Types (Part 5)

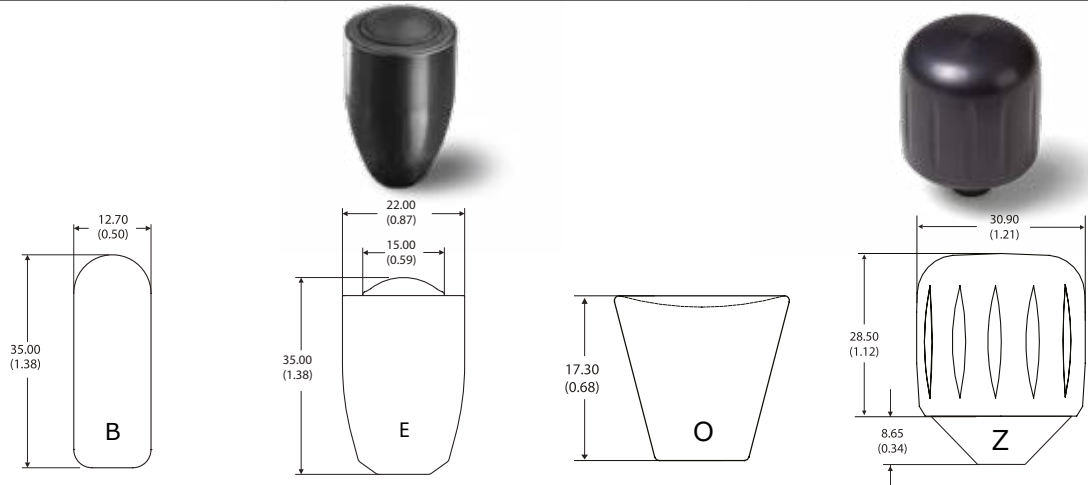

Handle Code	B	E	O	Z
Material	Aluminium	Aluminium	Nylon	Aluminium
Finish	Anodized	Anodised	Sparked Matt	Anodised
Standard colour	Black	Black	Black	Black
Notes	for 1-2 axes	for 1-2 axes with 1 Push-button	for 1-2 axes, low profile	3rd axis functionality (rotation)

### Handle Types (Part 6)

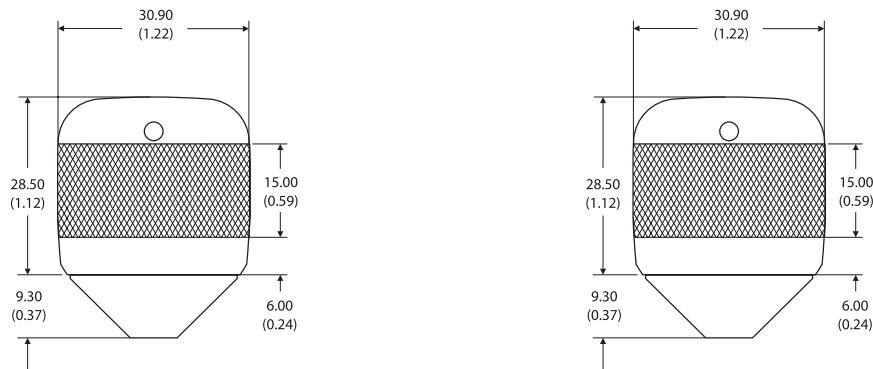

Handle Code	Q	QQ
Material	Aluminium	Aluminium
Finish	Anodized, knurled	Anodised, knurled
Standard colour	Black	Black
Notes	for 3 axes	for 1-2 axes

# Data Sheet for Joysticks

Finger Joystick

Series 844

## Spring return / guided feel

The standard force required for the deflection is 1.3 N. On request, also weaker (1.0 N) or stronger springs can be selected (1.6 N).



“Guided feel“ still allows the joystick handle to be deflected omni-directionally, but as the operation force needed for the main axes is slightly below the force needed for diagonal deflection the resulting impression is that of a “guided movement“.

## Limiters



Square - Option 6



Single Axis X - Option 1



Circular - Option 5



Single Axis Y - Option 2



Square rotated by 45°, “Diamond“ - Option 4



X/Y Plus “+“ - Option 3

## Mounting Options



### Drop-in of Joystick into panel cut-out.

For panel thickness < 3 mm, M3 x 16 countersunk machine screw are recommended. Also available with circular bezel.

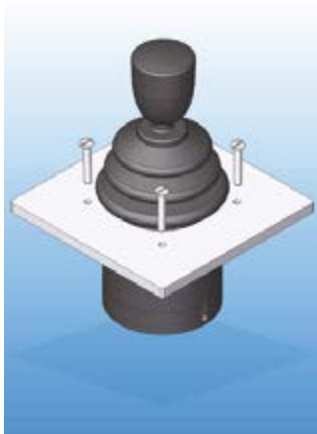
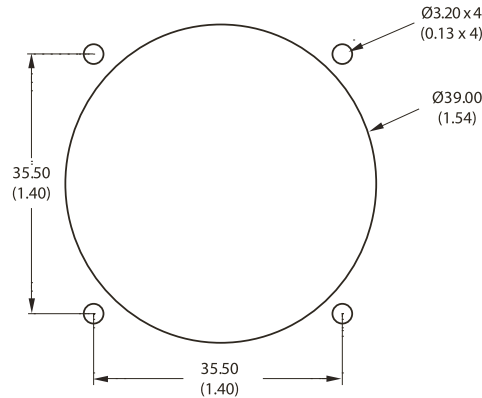

### Mounting of Joystick from beneath the panel.

No bezel needed. M3 machine screws recommended.

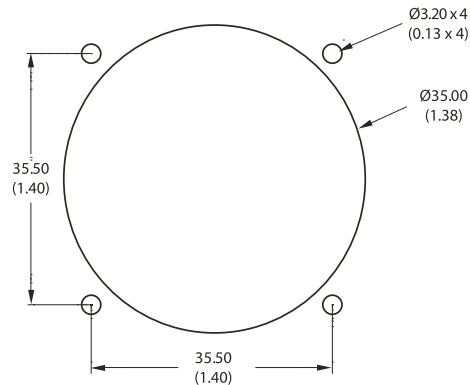

### Mounting with circular bezel from beneath the panel.

Base of boot must be brought through panel cut-out and held in place with the circular bezel. For panel thickness < 3 mm, M3 x 16 countersunk machine screw are recommended.

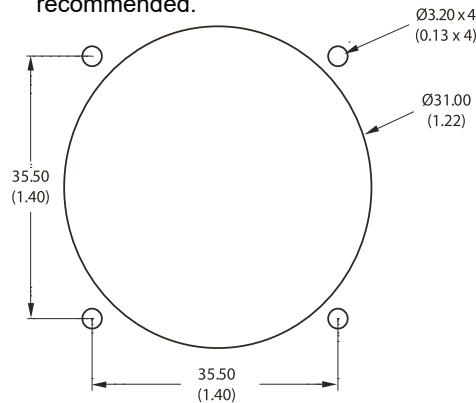

All Dimensions in mm

# Data Sheet for Joysticks

## Finger Joystick

Series 844

### Wiring for version without pushbutton or 1 pushbutton, analogue, PWM, non-redundant versions

Pin	Function	Colour
1	Ground	black
2	Center Tap (desc. see below)	green
3	Z-Axis	purple
4	Y-Axis	yellow
5	X-Axis	blue
6	Vsupply	red
7	Center Detect (desc. see below)	orange
8**	Pushbutton	orange
9**	Pushbutton	orange

Orientation / Polarity

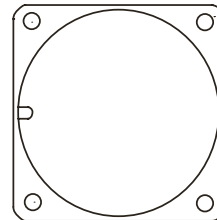
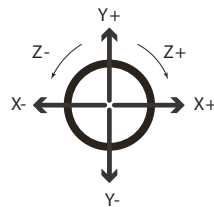

CABLES EXIT TO THE EAST WHEN VIEWED FROM ABOVE

Pin 8 (orange) —○—○— (orange) Pin 9

\*\* The both wires are separate connectors for the n.o. switch.

### Wiring for version with 2 pushbuttons, non-redundant versions, analogue, PWM,

Pin	Function	Colour
1	Ground	black
2	Center Tap (desc. see below)	green
3	Z-Axis	purple
4	Y-Axis	yellow
5	X-Axis	blue
6	Vsupply	red
7	Center Detect (desc. see below)	orange
8	Pushbutton 1	orange
9	Pushbutton 2	orange

The two buttons address two separate digital outputs HIGH/LOW on pin 8 and 9. Ground and supply voltage of the joystick (pin 1 and pin 6) are needed for this purpose.

### Cable harness for analogue and PWM versions

The joysticks are delivered with standard connection wires (2.54 mm raster, female, compatible to Molex KK series). For non-redundant versions without pushbutton, a 7-pin connector is delivered. For versions with pushbutton, a 9-pin connector is the default configuration (see the table above for pin configuration). The wire length is ca. 150 mm. Please contact us for custom cable configurations.

### Output impedance for analogue and PWM versions

The voltage outputs at the limits and at the center are specified for an infinite load at the outputs (no current flowing). Lower loads than 10 kOhms need to be avoided.

### Center Tap (CT) for analogue and PWM versions

The standard electronics (no redundancy) offers a center reference voltage output, that is set to 50% ( $\pm 1\%$ ) of the supply voltage. This output can be used to check the integrity of the power supply. Voltage readings outside the tolerances suggest a problem with the power supply.

Another function of this output is as a reference relative to the center position of the joystick. Measuring the voltage output relative to the CT output, rather than relative to ground, eliminates inaccuracies caused by the power supply.

### Center Detect (CD) for analogue and PWM versions

The standard electronics (no redundancy) offers a center detect output, which is 0 V if the joystick is inactive, but switches to high (5 V if operated with 5 V power supply) only if the joystick is operated.

In the internal electronics, this output is pulled high by a 2K2 resistor and is decoupled by a 100 nF capacitor to 0 V.

This output is designed for use in applications requiring an enable/disable signal that is separate from the main wipers. We do not recommend to use this as a safety feature or a method of "person-present" detection (deadman).



# Data Sheet for Joysticks

Finger Joystick

Series 844

## Termination for CAN outputs only

Pin	Function CAN J1939	Function CANopen	Colour
1	Supply (7 to 35 VDC)	Supply (7 to 35 VDC)	red
2	Ground	Ground	black
3	ID select MSB	Node ID select MSB	orange
4	ID select LSB	Node ID select LSB	blue
5	CAN High	CAN High	green
6	CAN Low	CAN Low	white

CAN output versions are supplied with on-board 6 way connector. Header specifications: JST S6B-PH-K-S(LF)(SN), 6 position, 2mm pitch, single row header (see drawing below).

## Drawing (analogue and PWM only)

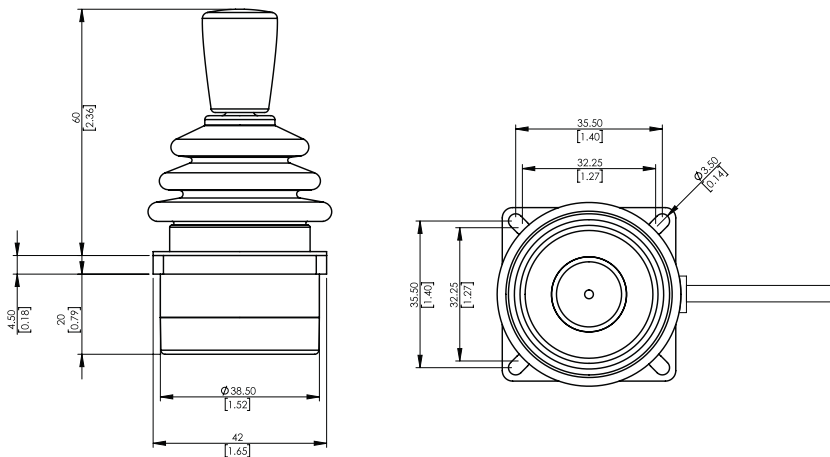

Dimensions in mm [inches]

## Drawing (CAN only)

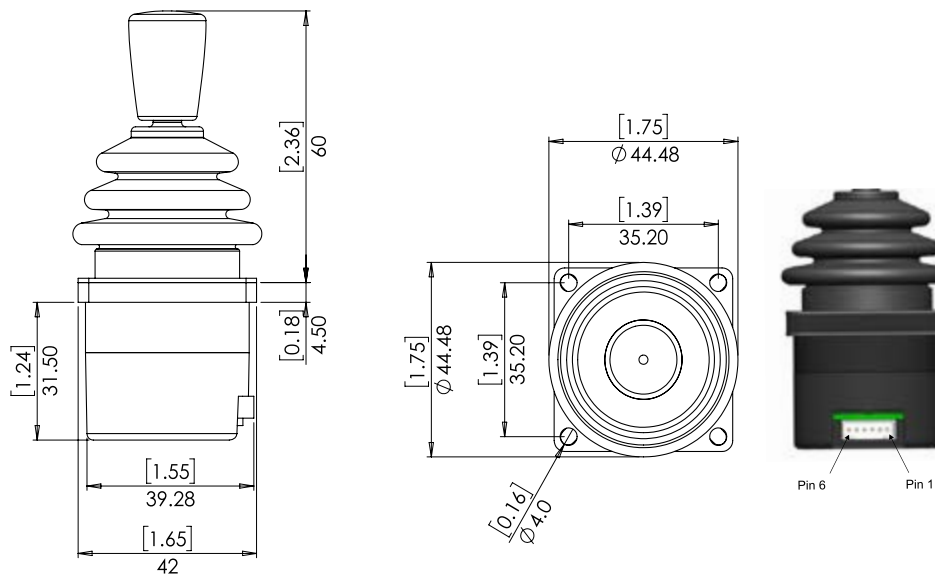

Dimensions in mm [inches]

# Data Sheet for Joysticks

Finger Joystick

Series 844

## Technical data CAN J1939 version (output option 7)

The 844 series can be configured with a maximum of 3 proportional axes and with a maximum of 2 buttons. The axis information and button data are transmitted via a CAN 2.0B-compatible physical interface. Two additional wires allow the address of the controller to be configured. The controller transmits its information in accordance with the SAE J1939-71 protocol.

Transmission repetition rate	50 ms
Terminal resistor	None
Baud rate	250 kbit/s
CAN ID format	29 bit (CAN 2.0B)
BJMI/EJMI interval time	20 ms

## Data CAN J1939-71 protocol (output option 7)

- Primary axis and Pushbutton data on Basic Joystick Message 1 (BJM1):
  - Priority: 3
  - PGN: 0xFDD6
  - Source address: 0x16<sup>(1)</sup>
  - Length of data field: 8 bytes

- Redundant axis and Pushbutton data on Extended Joystick Message 1 (EJM1):
  - Priority: 3
  - PGN: 0xFDD7
  - Source address: 0x16<sup>(1)</sup>
  - Length of data field: 8 bytes

- <sup>(1)</sup> Alternative source addresses can be configured by grounding the blue and / or orange wires:
- Source address = 0x16: ORANGE = floating, BLUE = floating (standard)
  - Source address = 0x26: ORANGE = floating, BLUE = grounded
  - Source address = 0x36: ORANGE = grounded, BLUE = floating
  - Source address = 0x46: ORANGE = grounded, BLUE = grounded

## BJM1 data field configuration (output option 7)

Start position (BYTE/BIT)	Length (BITS)	Function
1/1	2	Primary data X-axis, status neutral position
1/3	2	Primary data X-axis, status left position (minimum value)
1/5	2	Primary data X-axis, status right position (maximum value)
1/7 to 2/8	10	Primary data X-axis, axis position
3/1	2	Primary data Y-axis, status neutral position
3/3	2	Primary data Y-axis, status backward position (minimum value)
3/5	2	Primary data Y-axis, status forward position (maximum value)
3/7 to 4/8	10	Primary data Y-axis, axis position
6/5	2	Button 2 status
6/7	2	Button 1 status

# Data Sheet for Joysticks

Finger Joystick

Series 844

## EJM1 data field configuration (output option 7)

Start position (BYTE/BIT)	Length (BITS)	Function
5/1	2	Z axis primary data, neutral position status
5/3	2	Primary data Z axis status deflection counterclockwise
5/5	2	Primary data Z-axis status deflection clockwise
5/7 to 4/8	10	Primary data Z axis, axis position

\*Redundant outputs are available as a special version

## Technical data CANopen version (output option 8)

The 844 series can be configured with a maximum of 3 proportional axes and 2 buttons. Two additional lines allow the address of the controller to be configured. The following configuration applies to the CANopen® protocol.

Node ID:	20h
Baud rate:	250 kbit/s
Push button data:	Button status is transmitted in a 1 byte data frame with the identifier 1A0 (180h + node ID)
Axis data:	Axis data are transmitted in a 3 byte data frame with the identifier 2A0 (280h + node ID)
Heartbeat (500 ms):	720h (700h + node ID)
Axis resolution:	8 bit
Network management:	Autostart activated

Alternative node IDs can be configured by grounding the blue and/or orange wires:

- Node ID = 20H: ORANGE= floating, BLUE= floating (standard)
- Node ID = 21H: ORANGE= floating, BLUE= earthed
- Node ID = 22H: ORANGE= grounded, BLUE= floating
- Node ID = 23H: ORANGE= grounded, BLUE= grounded

## Button data (output option 8)

Identifier	1A0
Byte 0	Buttons 2:0

## Axis data (output option 8)

Identifier	2A0
Byte 0	A_IN0 [7:0]
Byte 1	A_IN1 [7:0]
Byte 2	A_IN2 [7:0]

## For higher quantities or on-going demand, additional options are available

- Redundant joystick versions with CAN-bus
- Other Baud rates 125 kbit/s, 500 kbit/s, 1 Mbit/s
- Customer-specific CAN addresses and output configuration