



HTx36 S
Solid Shaft



HTx36 HK
Clamp Hollow Shaft



HTx36 H
Screw Hollow Shaft

Key Features

- Ø36 aluminium metal housing
- Maximum life time expectation
- High continuous actuation shaft speeds
- High shaft loads
- Magnetic, gradient-based signal evaluation
- Digital signal processing
- Double ball bearings
- Protection: Shaft bearings IP65, option IP67, Housing IP68
- Operating temperature -30 to 85°C
- Measuring range 360° singleturn, up to 72000° multiturn
- Electrical connections M12 plug or round signal cable
- Cable/connector outlet radial or axial
- Programmable signal output function (factory or field-programmable/teach-in)

Applications

- Plant engineering
- Mechanical engineering
- Equipment manufacturing
- Driverless transport systems
- Medical equipment
- Special vehicles
- Industrial robots
- Wind turbines
- Motor control units
- Stage technology

	HTx36 (this data sheet):	HTx36E (separate data sheet):
Singleturn absolute encoders	<ul style="list-style-type: none"> ▪ Analogue voltage or current loop output (12 bit resolution) ▪ Analogue PWM output (12 bit resolution) ▪ Digital outputs SPI (14 bit) and SSI (10 to 18 bit resolution) ▪ Absolute linearity up to 0.6% 	<ul style="list-style-type: none"> ▪ Resolution up to 16 bit ▪ CANopen, CAN SAE J1939, SSI ▪ Patented technology for a system accuracy < 0.35°
Multiturn encoders	<ul style="list-style-type: none"> ▪ Programmable analogue voltage or current loop output (12 bit resolution) ▪ Not True-Power-On (max. 200 revolutions, 72000°, programmable) 	<ul style="list-style-type: none"> ▪ CANopen, CAN SAE J1939, SSI ▪ Patented battery and gear-less true-power-on multiturn technology (energy harvesting) ▪ up to 43 bit multiturn resolution
Incremental encoders	<ul style="list-style-type: none"> ▪ 1 to 20.000 Impulses per revolution (ppr.) ▪ Output Open Collector or TTL 	<ul style="list-style-type: none"> ▪ 1 to 16384 Impulses per revolution (ppr.) ▪ Outputs TTL or HTL ▪ Optional user-parameterizable index pulse (Z) position

General
Contents
Voltage/Current
Redundant
Analogue (HTA36)
PWM (HTP36)
Serial (HTS36)
Incremental (HTI36)
Multiturn HTA36 PM
Solid Shaft
Hollow shaft
Drawings
Mechanical Data
Accessories

HTx36 encoder – robust, ball bearing, sealed, with solid or hollow shaft

The HTx36 range of encoders is designed for use between simple and heavy duty applications. With a wide range of electronic and mechanical options, these contactless encoders in a Ø36 mm metal housing can be adapted to suit any application. Whether as incremental or absolute encoders, they cover a wide range of applications and, depending on the output electronics, are used in systems, laboratory equipment and medical devices, for example.

The HTx36 encoders are among the most robust encoders in the MEGATRON range. This is due to the solid aluminium housing, the high IP protection class and the double ball bearing stainless steel shaft, which withstands high axle loads and allows high actuation speeds. Signal processing is digital and based on magnetic recording of the measured values. The gradient based evaluation ensures high immunity to temperature variations and EMC influences. This technology overcomes the disadvantages of conventional Hall sensors. HTx36 encoders are designed for maximum durability, even surpassing the robust optical data acquisition. The number of defects or failures in encoders with this technology design is virtually zero, even after decades of use.

In addition to a wide range of standard options, the modular design of the HTx36 encoders enables optimum adaptation to the specific requirements of the application. In addition, the concept allows for timely customisation (even in small batches) based on a clearly structured pricing model. Typical modifications include customised shaft geometries, signal output functions, special cable lengths or customised electrical connection cables.

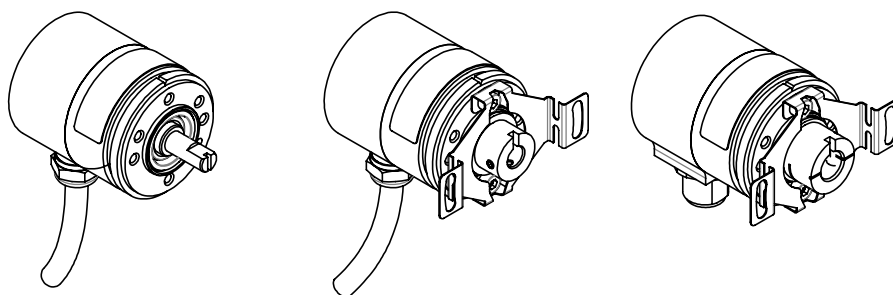

General
Contents
Redundant Voltage/Current Analogue (HTA36)
PWM (HTP36)
Serial (HTS36)
Incremental (HTI36)
Multiturn HTA36 PM
Hollow shaft Solid Shaft Drawings
Mechanical Data
Accessories

Table of Contents

1. GENERAL INFORMATION AND INTRODUCTION	1
2. ELECTRONIC OUTPUT VARIANTS AND ORDER CODES	4
a. Comparison Table	4
b. Absolute Single Turn Encoders	5
i. Analogue Current Loop or Voltage Output – HTA36	5
ii. Redundant Analogue Voltage Output – HTA36X	7
iii. Pulse Width Modulation (PWM) – HTP36	9
iv. Serial output SPI or SSI – HTS36	11
c. Incremental Encoders – HTI36	19
d. Multiturn Encoders with Analogue Output – HTA36PM	23
3. TECHNICAL DRAWINGS	26
a. Solid shaft (HTx36 S)	26
b. Drawings – Hollow Shaft with Screw Fixation (HTx36 H)	29
c. Hollow Shaft with Clamp Fixation (HTx36 HK)	32
4. MECHANICAL DATA, COMPLIANCE AND ENVIRONMENTAL SPECIFICATIONS	36
5. ORDER CODES – FULL OVERVIEW	38
6. ACCESSORIES	39

General
Contents
Redundant Voltage/Current Analogue (HTA36)
PWM (HTP36)
Serial (HTS36)
Incremental (HTI36)
Multiturn HTA36 PM
Hollow shaft Solid Shaft Drawings
Mechanical Data
Accessories

Series Overview

>>Please refer to the following sections for details

		Singleturn				Multiturn	
Series		HTI36	HTS36	HTA36	HTA36X	HTP36	HTA36PM
Electronics redundant		NO	NO	NO	YES	NO	NO
Output signal(s)		Incremental A, B, Z 1 to 20,000 ppr	Digital absolute SSI SPI	Analogue absolute 0 to 5 V 0 to 10 V 4 to 20 mA	Analogue absolute 0 to 5 V 0 to 10 V	PWM absolute 5 V / 244 Hz / PWM 10-90%	Analogue absolute 0 to 5 V 0 to 10 V 4 to 20 mA
Effective electrical angle of rotation		360°		7° ≤ α ≤ 360° (programmable in factory)		7° ≤ α ≤ 360° (programmable in factory)	0-10° to 0-72000° (programmable by user) factory programming 0 to 3600°
Resolution		-	SSI: 10-18 bit SPI: 14 bit	12 bit			
Supply voltage(s)	Output type		SPI	Analogue 0 to 5 V	Analogue 0 to 5 V	PWM	Analogue 0 to 5 V
	Supply voltage		5 V ± 10%	5 V ± 10% (ratiometric) or 24 V (9 to 30 V)	5 V ± 10%	5 V ± 10%	24 V (9 to 30 V)
	Output type	Open collector	SSI	Analogue 0 to 10 V	Analogue 0 to 10 V		Analogue 0 to 10 V
	Supply voltage	4.8 to 42 V	4.8 to 42 V	24 V (15 to 30 V)	24 V (15 to 30 V)		24 V (15 to 30 V)
	Output type			Current loop 4 to 20 mA			Current loop 4 to 20 mA
	Supply voltage			24 V (9 to 30 V)			24 V (11 to 30 V)
Programming options							
Programmable by customer		NO	NO	NO	NO	NO	YES
Programmable ex works		YES	YES	YES	YES	YES	YES

General
Contents
Voltage/Current
Redundant
Analogue (HTA36)
PWM (HTP36)
Serial (HTS36)
Incremental (HTI36)
Multiturn HTA36 PM
Solid Shaft
Hollow shaft
Drawings
Mechanical Data
Accessories

Series HTA36 – singleturn, analogue output, not redundant

Key features HTA36

- Analogue outputs 0 to 5 V, 0 to 10 V, 4 to 20 mA
- Redundant versions available – see separate section
- Several factory programming possibilities
- Supply voltages: 5 VDC ±10%, 15 to 30 VDC, 9 to 30 VDC



Electrical data

Effective electrical angle of rotation 1.)	7° ≤ α ≤ 360° (programmable in factory), ±0.5°		
Independent linearity (best straight line) 1.)	±0.3% @ 360°		
Absolute Linearity 1.)	±0.6% @ 360°		
Output signal	0 to 5 V ratiometric	0 to 10 V	4 to 20 mA
Resolution	12 Bit		
Update rate	200 µs		
Supply voltage	5 V ±10%	15 to 30 V	9 to 30 V
Power consumption (no load)	≤ 18 mA		
Output load	≥ 5 kOhm		≤ 500 Ohm
Insulation voltage 1.)	1000 VAC @ 50 Hz, 1 min		
Insulation resistance 1.)	2 MOhm @ 500 VDC, 1 min		
MTTF (SN29500-2005-1)	1173a	965a	379a

1.) According IEC 60393

Cable and pin assignment

Function:	Option PG(R)	Option M12(R)
VSUP	red	PIN 1
GND	black	PIN 2
OUT	brown	PIN 3
-	-	PIN 4 n/c

Plug M12 (R) HTA36 – pin assignment

Type 1 (4 pole)

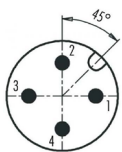

The orientation of the connector relative to the encoder housing is not defined and differs from one encoder to the next. When using angled connectors in combination with axial outlet, the orientation of the cable outlet is thus not defined.

If you need a defined orientation of the cable outlet, please choose our housings with radial cable outlet and use straight mating connectors.

Order code HTA36 – singleturn, not redundant									
Description	Selection: standard= black/bold , possible options= <i>grey/italic</i>								
Series HTA36	HTA36								
Shaft type: Solid shaft Hollow shaft with screw fixation <i>Hollow shaft with clamp fixation</i>	S H <i>HK</i>								
Shaft diameter, shaft length: Shaft diameter Ø 6 mm <i>Shaft diameter Ø 8 mm</i> <i>Shaft diameter Ø 6.35 mm</i> <i>User-defined shaft diameter [mm]</i> <i>Ø ≤ 8 mm in connection with option S</i> <i>Ø ≤ 10 mm in connection with option H or HK</i> <i>Ø ≤ 12 mm exclusively in connection with Option H</i>		6 <i>8</i> <i>6,35</i> <i>X</i>							
Multiplication symbol [x]: For solid shaft (S) For hollow shaft H or HK				x <i>-</i>					
Visible shaft length: Shaft length 16.5 mm for solid shaft (S) Shaft length for hollow shafts H or HK <i>User-defined shaft length for solid shaft S [mm]</i>					16,5 <i>-</i> <i>XX</i>				
Supply voltage / Output signal: VSUP=24 V (9 to 30 V) / OUT=4 to 20 mA VSUP=24 V (15 to 30 V) / OUT=0 to 10 V VSUP=5 V (4.5 to 5.5 V) / OUT=0 to 5 V (ratiometric) <i>VSUP=24 V (9 to 30 V) / OUT=0 to 5 V</i>						2442 2410 0505 <i>2405</i>			
Sense of rotation: (when looking at the shaft from the front) Sense of rotation CW (output signal increases clockwise) <i>CCW</i> (output signal increases counter clockwise)							CW <i>CCW</i>		
Electrical angle: Electrical angle 360° <i>User-defined effective electrical angle (≥7°, positive integer)</i>								360 <i>XXX</i>	
Shaft sealing: Without shaft sealing (IP65) <i>With shaft sealing (IP67)</i>								<i>-</i> D	
Electrical connection, cable length, position: 1 m round cable, axial 1 m round cable, radial Plug M12, axial Plug M12, radial <i>Round cable, customer-specific cable length [X,XX m], axial</i> <i>Round cable, customer-specific cable length [X,XX m], radial</i>									PG PGR M12 M12R <i>PG X,XX</i> <i>PGR X,XX</i>

Order example HTA36 H – hollow shaft, singleturn, analogue output, not redundant
Requirements: Hollow shaft Ø 6.00 mm, fixation of the application side shaft in the hollow shaft by means of grub screw, $V_{SUP} = 24 V$ / OUT = 4 to 20 mA, sense of rotation CW, electrical angle 360°, no shaft sealing, round cable 1 m, cable outlet position axial (in dependency to the shaft)
Example for order code: HTA36 H 6 2442 CW360 PG

General
Contents
Redundant
Voltage/Current
Analogue (HTA36)
PWM (HTP36)
Serial (HTS36)
Incremental (HTI36)
Multiturn HTA36 PM
Solid Shaft
Drawings
Hollow shaft
Mechanical Data
Accessories

Series HTA36X – singleturn, redundant

Key features HTA36X :

- Independent signal processing. The HTA36X rotary encoder electronics are based mainly on one 3D-Hall IC in which two semiconductor chips independently capture, evaluate and output the measured values
- Supply voltage, signal output and ground are galvanically insulated => separate electrical connections
- Supply voltages: 2 x 5 VDC or 2 x 15 to 30 VDC
- Signal outputs: 2 x 0 to 5 V or 2 x 0 to 10 V

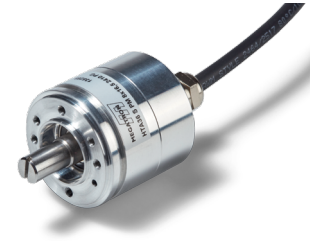

Electrical data HTA36X – singleturn, redundant

Effective electrical angle of rotation 1.)	7° ≤ α ≤ 360° (programmable at factory), ±0.5°	
Independent linearity (best straight line) 1.)	±0.3% @ 360°	
Absolute Linearity 1.)	±0.6% @ 360°	
Output signal	0 to 5 V ratiometric	0 to 10 V
Resolution	12 Bit	
Update rate	200 μs	
Supply voltage	5 V ±10%	15 to 30 V
Power consumption (no load)	≤ 23 mA	
Output load	≥ 5 kOhm	
Insulation voltage 1.)	1000 VAC @ 50 Hz, 1 min	
Insulation resistance 1.)	2 MOhm @ 500 VDC, 1 min	
MTTF (SN29500-2005-1)	613a	202a

1.) According IEC 60393

Cable and pin assignment HTA36X – singleturn, analogue output, redundant

Function:	Option PG(R)	Option M12(R)
VSUP 1	red	PIN 1
OUT 1	brown	PIN 2
GND 1	black	PIN 3
GND 2	green	PIN 4
OUT 2	yellow	PIN 5
VSUP 2	orange	PIN 6
-	-	PIN 7 n/c
-	-	PIN 8 n/c

Plug M12 (R) HTA36X – pin assignment

Type 2 (8 pole)

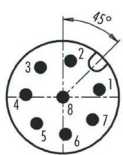

The orientation of the connector relative to the encoder housing is not defined and differs from one encoder to the next. When using angled connectors in combination with axial outlet, the orientation of the cable outlet is thus not defined.

If you need a defined orientation of the cable outlet, please choose our housings with radial cable outlet and use straight mating connectors.

Order code HTA36X – solid or hollow shaft, singleturn, redundant									
Description	Selection: standard= black/bold , possible options= <i>grey/italic</i>								
Series HTA36X	HTA36X								
Shaft type: Solid shaft Hollow shaft with screw fixation <i>Hollow shaft with clamp fixation</i>		S H <i>HK</i>							
Shaft diameter, shaft length: Shaft diameter Ø 6 mm <i>Shaft diameter Ø 8 mm</i> <i>Shaft diameter Ø 6.35 mm</i> <i>User-defined shaft diameter [mm]</i> <i>Ø ≤ 8 mm in connection with option S</i> <i>Ø ≤ 10 mm in connection with option H or HK</i> <i>Ø ≤ 12 mm exclusively in connection with Option H</i>			6 8 6,35 X						
Multiplication symbol [x]: For solid shaft (S) For hollow shaft H or HK				x -					
Visible shaft length: Shaft length 16.5 mm for solid shaft (S) Shaft length for hollow shafts H or HK <i>User-defined shaft length for solid shaft S [mm]</i>					16,5 - XX				
Supply voltage / Output signal: V_{SUP} = 5 V (4.5 to 5.5 V) / OUT = 0 to 5 V (ratiometric) V_{SUP} = 24 V (15 to 30 V) / OUT = 0 to 10 V						0505 2410			
Sense of rotation output 1: Sense of rotation CW (output signal increases clockwise) <i>Sense of rotation CCW</i> (output signal increases counter clockwise)							CW <i>CCW</i>		
Sense of rotation output 2: Sense of rotation CW (output signal increases clockwise) <i>Sense of rotation CCW</i> (output signal increases counter clockwise)							CW <i>CCW</i>		
Electrical angle: Electrical angle 360° <i>User-defined effective electrical angle (≥7°, positive integer)</i>								360 XXX	
Shaft sealing: Without shaft sealing (IP65) <i>With shaft sealing (IP67)</i>									- D
Electrical connection, cable length, position: 1 m round cable, axial 1 m round cable, radial Plug M12, axial Plug M12, radial <i>Round cable, customer-specific cable length [X,XX m], axial</i> <i>Round cable, customer-specific cable length [X,XX m], radial</i>									PG PGR M12 M12R <i>PG X,XX</i> <i>PGR X,XX</i>

Order example HTA36X S - solid shaft, singleturn, analogue output, not redundant	
Requirements: Solid shaft Ø 6.00 mm, shaft length 16.5 mm, VSUP=24 V / OUT=0 to 10 V, signal 1 sense of rotation CW, signal 2 sense of rotation CW, electrical angle 360°, no shaft sealing, round cable 1 m, cable outlet position axial (in dependency to the shaft)	
Example for order code: HTA36X S 6x16,5 2410 CW CW360 PG	

General
Contents
Redundant Voltage/Current Analogue (HTA36)
PWM (HTP36)
Serial (HTS36)
Incremental (HTI36)
Multiturn HTA36 PM
Solid Shaft Drawings
Hollow shaft Drawings
Mechanical Data
Accessories

Series HTP36 – singleturn, not redundant

Key features HTP36:

- PWM signal output
- Frequency 244 Hz (constant)
- Pulse width (duty cycle) 10% (0°) to 90% (360°)
- Supply voltage: 5 VDC +/-10%



Electrical data HTP36 – singleturn, not redundant

Effective electrical angle of rotation 1.)	$7^\circ \leq \alpha \leq 360^\circ$ (programmable in factory), $\pm 0.5^\circ$
Independent linearity (best straight line) 1.)	$\pm 0.4\%$ @ 360°
Absolute Linearity 1.)	$\pm 0.6\%$ @ 360°
Output signal	PWM (pulse width modulation)
Output signal voltage	5 V
Carrier frequency	244 Hz (constant)
Minimum duty cycle	10%, equal to app. 0.4 ms
Maximum duty cycle	90%, equal to app. 3.5 ms
Resolution	12 Bit
Supply voltage	5 V $\pm 10\%$
Power consumption (no load)	≤ 10 mA
Output load	≥ 5 kOhm
Insulation voltage 1.)	1000 VAC @ 50 Hz, 1 min
Insulation resistance 1.)	2 MOhm @ 500 VDC, 1 min
MTTF (SN29500-2005-1)	1267a

1.) According IEC 60393

Function description HTP36

The HTP36 provides a constant carrier frequency with 244 Hz at the signal output, with HIGH and LOW signal levels which have a constant signal amplitude. A constant carrier frequency means a constant length of the period duration. The duty cycle and thus the pulse width changes in dependency of the rotating angle between 10% to 90% relative to the signal period. If the CW option is selected, the duty cycle increases clockwise when turning the shaft clockwise. If the CCW option is selected, the duty cycle decreases clockwise if the shaft is turned clockwise. Normally no signal conversion is required for further processing of the output signal, because many μ Controllers already have an input for PWM signals.

Cable and pin assignment HTP36 – singleturn, analogue output, not redundant

Function:	Option PG(R)	Option M12(R)
VSUP	red	PIN 1
GND	black	PIN 2
OUT	brown	PIN 3
-	-	PIN 4 n/c

Plug M12 (R) HTP36 – pin assignment

Type 1 (4 pole)

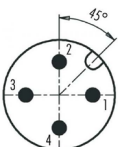

The orientation of the connector relative to the encoder housing is not defined and differs from one encoder to the next. When using angled connectors in combination with axial outlet, the orientation of the cable outlet is thus not defined.

If you need a defined orientation of the cable outlet, please choose our housings with radial cable outlet and use straight mating connectors.

General
Contents
Redundant
Voltage/Current
Analogue (HTA36)
PWM (HTP36)
Serial (HTS36)
Incremental (HTI36)
Multiturn (HTA36 PM)
Solid shaft
Hollow shaft
Drawings
Mechanical Data
Accessories

Order code HTP36 - solid or hollow shaft, singleturn, analogue signal output, not redundant									
Description	Selection: standard= black/bold , possible options= <i>grey/italic</i>								
Series HTP36	HTP36								
Shaft type: Solid shaft Hollow shaft with screw fixation <i>Hollow shaft with clamp fixation</i>	S H <i>HK</i>								
Shaft diameter, shaft length: Shaft diameter Ø 6 mm <i>Shaft diameter Ø 8 mm</i> <i>Shaft diameter Ø 6.35 mm</i> <i>User-defined shaft diameter [mm]</i> <small>Ø ≤ 8 mm in connection with option S Ø ≤ 10 mm in connection with option H or HK Ø ≤ 12 mm exclusively in connection with Option H</small>			6 8 6,35 <i>X</i>						
Multiplication symbol [x]: For solid shaft (S) For Hollow shaft H or HK				x -					
Visible shaft length: Shaft length 16.5 mm for solid shaft (S) Shaft length for hollow shafts H or HK <i>User-defined shaft length for solid shaft S [mm]</i>					16,5 - <i>XX</i>				
Supply voltage / Output signal: V_{SUP} = 5 V (4.5 to 5.5 V) / OUT = 5 V / 244 Hz / PWM 10-90%						05PWM			
Sense of rotation: Sense of rotation CW (output signal increases clockwise) <i>Sense of rotation CCW</i> (output signal increases counter clockwise)						CW <i>CCW</i>			
Electrical angle: Electrical angle 360° <i>User-defined effective electrical angle</i> <small>(≥ 7°, positive integer)</small>							360 <i>XXX</i>		
Shaft sealing: Without shaft sealing IP65 <i>With shaft sealing (IP67)</i>								- <i>D</i>	
Electrical connection, cable length, position: 1 m round cable, axial 1 m round cable, radial Plug M12, axial Plug M12, radial <i>Round cable, customer-specific cable length [X,XX m], axial</i> <i>Round cable, customer-specific cable length [X,XX m], radial</i>									PG PGR M12 M12R <i>PG X,XX</i> <i>PGR X,XX</i>

Order example HTP36 - solid shaft, singleturn, PWM output, not redundant

Requirements:
Solid shaft Ø 6.00 mm, shaft length 16.5 mm, VSUP=5 V (4.5 to 5.5 V) / OUT=5 V / 244 Hz / PWM 10-90 %, sense of rotation CW, electrical angle 360°, no shaft sealing, round cable 1 m, cable outlet (in dependency to the shaft)

Example for order code:
HTP36 S 6x16,5 05PWM CW360 PG

Order example HTP36 - hollow shaft, singleturn, PWM output, not redundant

Requirements:
Hollow shaft Ø 6.00 mm, fixation of the applications side shaft in the hollow shaft by means of grub screw, VSUP=5 V (4.5 to 5.5 V) / OUT=5 V / 244 Hz / PWM 10-90 %, sense of rotation CW, electrical angle 360°, no shaft sealing, round cable 1 m, cable outlet position axial (in dependency to the shaft)

Example for order code:
HTP36 H 6 05PWM CW360 PG

General
Contents
Redundant
Voltage/Current
Analogue (HTA36)
PWM (HTP36)
Serial (HTS36)
Incremental (HTI36)
Multiturn (HTA36 PM)
Solid Shaft
Drawings
Hollow shaft
Mechanical Data
Accessories

Series HTS36 – singleturn, digital output, not redundant

Key features HTS36:

- SPI interface with 14 bit resolution and 5 V input voltage
Attention: Signal transmission only possible via short signal lines
- SSI interface with 10-18 bit resolution and wide input range (4.8 to 42 V)



Electrical data HTS36 – singleturn, digital output, not redundant

Output signal	SPI	SSI
Effective electrical angle of rotation 1.)	360°	
Independent linearity (best straight line) 1.)	±0,3% @ 360°	please contact us
Absolute linearity 1.)	±0,6% @ 360°	please contact us
Resolution	14 Bit	10-18 Bit
Update rate	200 µs	18 µs
Supply voltage	5 VDC ±10 %	4.8 to 42 V
Power consumption (no load)	≤ 12 mA	≤ 24 mA (for 5 V input)
Insulation voltage 1.)	1000 VAC @ 50 Hz, 1 min	
Insulation resistance 1.)	2 MOhm @ 500 VDC, 1 min	
MTTF (SN29500-2005-1)	2046a	800a

1.) According IEC 60393

Connector types M12 (R) HTS36 – pin numbering

Type 2 (8 pole)

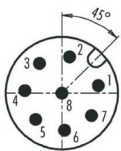

The orientation of the connector relative to the encoder housing is not defined and differs from one encoder to the next. When using angled connectors in combination with axial outlet, the orientation of the cable outlet is thus not defined.

If you need a defined orientation of the cable outlet, please choose our housings with radial cable outlet and use straight mating connectors.

General
Contents
Voltage/Current
Redundant
Analogue (HTA36)
PWM (HTP36)
Serial (HTS36)
Incremental (HTI36)
Multiturn HTA36 PM
Solid Shaft
Hollow shaft
Drawings
Mechanical Data
Accessories

Order Code HTS36 – solid or hollow shaft, singleturn, not redundant, SSI interface

Description	Selection: standard=black/bold , possible <i>options=grey/italic</i>									
Series HTS36	HTS36									
Shaft type: Solid shaft Hollow shaft with screw fixation <i>Hollow shaft with clamp fixation</i>		S H <i>HK</i>								
Shaft diameter, shaft length: Shaft diameter Ø 6 mm <i>Shaft diameter Ø 8 mm</i> <i>Shaft diameter Ø 6.35 mm</i> <i>User-defined shaft diameter [mm]</i> <small>Ø ≤8 mm in connection with option S Ø ≤10 mm in connection with option H or HK Ø ≤12 mm exclusively in connection with option H</small>			6 <i>8</i> <i>6,35</i> <i>X</i>							
Multiplication symbol [x]: For solid shaft (S) For Hollow shaft H or HK					x <i>-</i>					
Visible shaft length: Shaft length 16.5 mm for solid shaft (S) Shaft length for hollow shaft H or HK <i>User-defined shaft length for solid shaft S [mm]</i>						16,5 <i>-</i> <i>XX</i>				
Supply voltage / Output signal: 4.8 to 42 V / SSI, 16 Bit resolution <i>4.8 to 42 V / SSI, custom resolution 10 to 18 bit</i> 5 VDC ± 10% / SPI (14 Bit)							SSI 16 <i>SSI [10-18]</i> <i>05SPI</i>			
Shaft sealing: Without shaft sealing (IP65) <i>With shaft sealing (IP67)</i>								- <i>D</i>		
Electrical connection, cable length, position: 1 m round cable, axial 1 m round cable, radial Plug M12, axial Plug M12, radial <i>Round cable, customer-specific cable length [X,XX m], axial</i> <i>Round cable, customer-specific cable length [X,XX m], radial</i>									PG PGR M12 M12R <i>PG X,XX</i> <i>PGR X,XX</i>	

Order example HTS36 – solid shaft, singleturn, serial output, not redundant

Requirements: Solid shaft Ø 6.00 mm, shaft length 16.5 mm, electronics: 12 Bit/SSI, no shaft sealing, round cable 1 m, cable outlet position axial
Example for order code: HTS36 S 6x16,5 SSI 12 PG

General
Contents
Redundant
Voltage/Current
Analogue (HTA36)
PWM (HTP36)
Serial (HTS36)
Incremental (HTI36)
Multiturn (HTA36 PM)
Solid Shaft
Hollow shaft
Drawings
Mechanical Data
Accessories

Order example HTS36 – hollow shaft, singleturn, serial output, not redundant
Requirements:

Hollow shaft Ø 6,00 mm, fixation of the applications side shaft in the hollow shaft by means of grub screws, electronics 12Bit/24VDC/SSI, no shaft sealing, round cable 1 m, cable outlet position axial

Example for order code:

HTS36 H 6 SSI 12 PG

Cable and pin assignment HTS36 - singleturn, SSI interface, not redundant

Function:	Option PG(R)	Option M12(R)
GND	black	PIN 1
VSUP	red	PIN 2
CLK+	brown	PIN 3
CLK-	orange	PIN 4
DATA+	yellow	PIN 5
DATA-	green	PIN 6
-	-	PIN 7 n/c
-	-	PIN 8 n/c

Cable and pin assignment HTS36 - singleturn, SPI interface, not redundant

Function:	Option PG(R)	Option M12(R)
VSUP	red	PIN 1
GND	black	PIN 2
CS, MOSI	yellow	PIN 3
CLK	green	PIN 4
DATA	orange	PIN 5
-	brown n/c	PIN 6 n/c
-	-	PIN 7 n/c
-	-	PIN 8 n/c

Synchronous Serial Interface (SSI) - A simple yet robust interface

The synchronous serial interface (SSI) is a serial interface, i.e. the individual bits are transmitted in chronological order. The basis of data transmission is a shift register in which the encoder provides its current measured value. The rotary encoders function as so-called SSI slaves, because they only supply the values from the shift register at the DO (data out) output on receipt of a clock sequence sent out by the SSI master, the so-called "clock" signal (CLK). This clock signal is applied to the CLK input of the encoder. Both the clock signal and the data signal are transmitted differentially, which makes this type of data interface particularly robust against interference. In short, SSI enables the memory of a sensor to be read out reliably from an external source.

Data transmission

The SSI electronics of the encoder reacts to the first falling edge that arrives via the CLK line of the master, loads the current data into the register and transmits it bit by bit to the receiver with each rising edge of the clock. The composition of the transmitted information is not standardised and varies from manufacturer to manufacturer, sometimes even from product to product.

In MEGATRON's encoders, the position information is transmitted first (starting with the Most Significant Bit MSB, ending with the Least Significant Bit LSB). The maximum value of this information is limited by the number of bits transmitted. This is also the resolution of the measurement data. For example, a resolution of 10 bits corresponds to a number of $2^{10} = 1024$ steps, which are divided over the angular range of 360° . Thus, after receiving the position information, it is easy to calculate back to the absolute angle, because each single step would correspond to $360/1024 = 0.35^\circ$.

The position information is followed by a bit sequence of status data that can be of great interest for the application. This includes, for example, the status of the electronics (readiness, correct supply voltage), but also whether the magnetic field acting on the Hall sensor is within the permissible limits (i.e. the distance of the magnet from the sensor). The last bit is the parity bit. This takes the values HIGH or LOW as required, so that the encoder always sends an even number of bits (even parity). The receiver, i.e. the SSI master, must be set to the total length of the transmitted information including the parity bit.

At the end of the process, the master usually does not send any further edges to the encoder via the CLK line. The encoder then waits for a time t_m , (retriggerable monoflop) since the last CLK edge and then updates the data in the shift register. This is therefore the minimum pause time between two consecutive clock sequences when the master requires new, updated measurement data. The exact protocol description of the HTS encoders follows on the next page

Ring shift

However, if clock edges continue to be sent, then the encoder will start transmitting the same data set repeatedly after a zero bit. This procedure is also called ringshift. This makes sense, for example, if the parity bit would be incorrect from the master's point of view, if the data is otherwise corrupt and a new transmission is therefore requested, or if a higher transmission reliability is generally desired by comparing multiple transmissions of the same data. With ring shift, the transmission is also terminated and the latest measurement data is only loaded into the register again when no more clock signals arrive at the encoder for a minimum time t_m .

Early stop

The transmission of the data can be interrupted by the master at any time, e.g. also after the 10th bit. Even then, the internal timer (monoflop) expires, causing the data in the register to be reloaded after the time t_m . In this way, for example, only a part of the encoder data can be read out (e.g. 10 of the available 16 bits, no status data at all) and a higher update rate can be achieved, as the remaining information is simply omitted.

Notes on cable length

The higher the transmission rate (clock rate), the smaller the realisable cable length with SSI. These are physical limits that are not limited by the sensor product itself. A simple blanket statement about the actual realisable length is not easily possible.

The cable length that can actually be realised in the application is influenced by the following factors:

- Quality and design of the cable (shielding, conductor cross-section, conductor resistance, twisted cores, etc.).
- Ambient conditions (sources of interference such as motors, etc.)

We explicitly refer to the RS-422 standard regarding cable lengths.

Protocol description – Synchronous Serial Interface (SSI)

The HTS25K SSI encoder provides a 10-bit to 18-bit absolute position output, while 16 bit is the standard (ex works) configuration. This means that the full rotation angle (360°) is divided into steps of the respective resolution (16 bits yields 65.536 steps of approx. 0.005 degrees).

Standard configuration (16 bit output) yields the following pulse train, consisting both of position and status data:



The data structure for any resolution is as follows:

Position data (10 to 18 bits)				Status (7-bit)							Parity 1 bit
MSB	MSB-1	...	LSB	RDY	MHI	MLO	OV	UV	MEM	TRK	PAR

Abbreviation	Description
MSB to LSB	n-bits position data, selectable from 10 to 18 bits ex works, standard is 16 bit
RDY	The encoder is ready (if value is HIGH).
MHI	This indicates that the magnet strength detected by the Hall chip is too strong. If this is consistently HIGH, change to a weaker magnet or increase the distance between the encoder and the magnet. The value for this alarm is displayed as 1.
MLO	This indicates that the magnet strength detected by the Hall chip is too weak. If this is consistently HIGH, change to a stronger magnet or decrease the distance between the encoder and the magnet. The value for this alarm is displayed as 1.
OV	Overvoltage error at Hall Chip if HIGH. Might indicate defective voltage regulator (encoder's internal regulator).
UV	Undervoltage error if HIGH. Might indicate too low input voltage or defective voltage regulator (encoder's internal regulator).
MEM	If HIGH, a memory corruption has occurred. Perform a power cycle to reload the memory.
TRK	This indicates that the angular error has exceeded 5° within 5 ms. When this value stays at HIGH, perform a power-cycle to re-initialize the sensor.
PAR	Parity is even

Data is transmitted according to the following timing diagram:

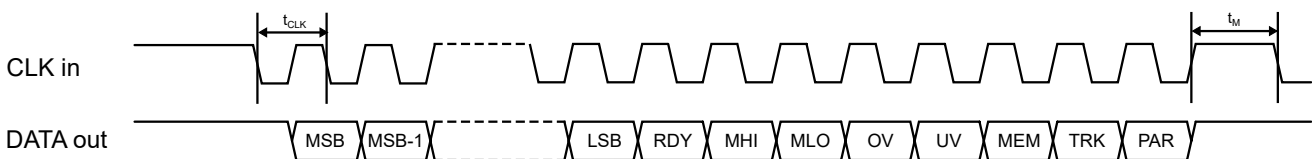

Symbol	Description	Min.	Typ.	Max.
t_{CLK}	Serial clock period	4 μ s		$t_{M/2}$
t_M	monoflop, time between two successive SSI reads		16.5 μ s	18 μ s

Data is latched on the first CLK falling edge and is transmitted on the next falling edge. Both signals are transmitted differentially and therefore have 2 connections (+/-) each. Data will be refreshed when the next monoflop (t_M) expires. If another clock train is sent before this time expires, the same position data is output, and the data is separated by a single low bit:

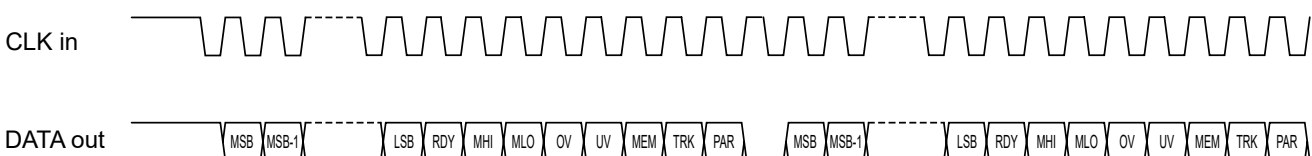

Protocol description – Serial Peripheral Interface (SPI)

Introduction

The encoder is configured as a Slave node. The serial protocol of the is a three wires protocol (/SS, SCLK, MOSI-MISO):

- /SS output is a 5 V tolerant digital input
- SCLK output is a 5 V tolerant digital input
- MOSI-MISO output is a 5 V tolerant open drain digital input/output

Basic knowledge of the standard SPI specification is required for the good understanding of the present section.

Even clock changes are used to sample the data. The positive going edge shifts a bit to the Slave's output stage and the negative going edge samples the bit at the Master's input stage.

MOSI (Master Out Slave In)

The Master sends a command to the Slave to get the angle information.

MISO (Master In Slave Out)

The MISO of the slave is an open-collector stage. Due to the capacitive load, a >1 kΩ pull-up is used for the recessive high level (in fast mode). Note that MOSI and MISO use the same physical wire of the ETS25.

/SS (Slave Select)

The /SS output enables a frame transfer. It allows a re-synchronization between Slave and Master in case of a communication error.

Master Start-Up

/SS, SCLK, MISO can be undefined during the Master start-up as long as the Slave is re-synchronized before the first frame transfer.

Slave Start-Up

The slave start-up (after power-up or an internal failure) takes 16 ms. Within this time /SS and SCLK is ignored by the Slave. The first frame can therefore be sent after 16 ms. MISO is Hi-Z (i.e. Hi-Impedance) until the Slave is selected by its /SS input. The encoder will cope with any signal from the Master while starting up.

Timing

To synchronize communication, the Master deactivates /SS high for at least t5 (1.5 ms). In this case, the Slave will be ready to receive a new frame. The Master can re-synchronize at any time, even in the middle of a byte transfer. Note: Any time shorter than t5 leads to an undefined frame state, because the Slave may or may not have seen /SS inactive.

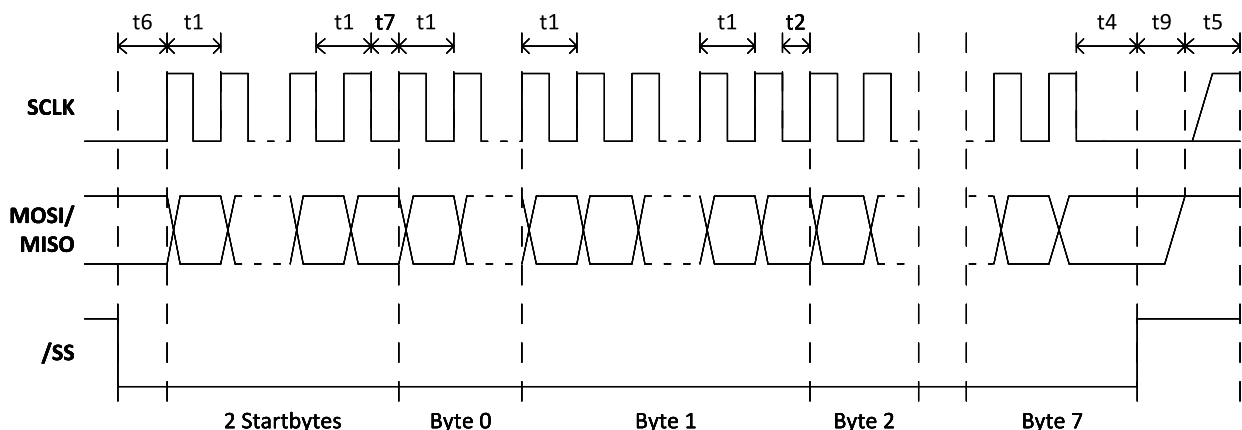

General
 Contents
 Voltage/Current Analogue (HTA36)
 Redundant Analogue (HTA36)
 PWM (HTP36)
 Serial (HTS36)
 Incremental (HTI36)
 Multiturn HTA36 PM
 Solid Shaft Drawings
 Hollow shaft Drawings
 Mechanical Data
 Accessories

Protocol description – Serial Peripheral Interface (SPI) (continuation)
Description Timings

Timings	Min	Max	Remarks
t1	2.3 μ s	-	No capacitive load on MISO. t1 is the minimum clock period for any bits within a byte.
t2	12.5 μ s	-	t2 the minimum time between any other byte
t4	2.3 μ s	-	Time between last clock and /SS=high=chip de-selection
t5	300 μ s	-	Minimum /SS = Hi time where it's guaranteed that a frame re-synchronizations will be started
t5	0 μ s	-	Maximum /SS = Hi time where it's guaranteed that NO frame re-synchronizations will be started.
t6	2.3 μ s	-	The time t6 defines the minimum time between /SS = Lo and the first clock edge
t7	15 μ s	-	t7 is the minimum time between the StartByte and the Byte0
t9	-	< 1 μ s	Maximum time between /SS = Hi and MISO Bus High Impedance
T _{Startup}	-	< 10 ms	Minimum time between reset-inactive and any master signal change

Slave Reset

On internal soft failures the Slave resets after 1 second or after an (error) frame is sent. On internal hard failures the Slave resets itself. In that case, the Serial Protocol will not come up. The serial protocol link is enabled only after the completion of the first synchronization (the Master deactivates /SS for at least t5).

Frame Layer
Command Device Mechanism

Before each transmission of a data frame, the Master should send a byte AAh to enable a frame transfer. The latch point for the angle measurement is at the last clock before the first data frame byte.

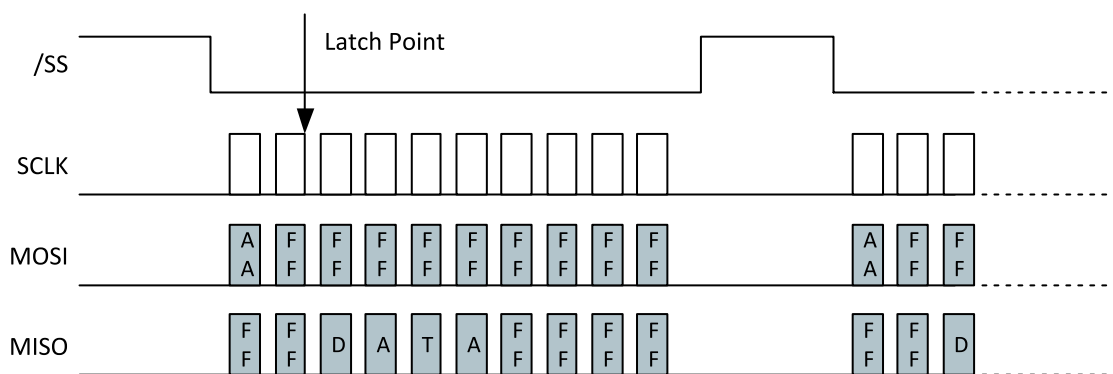
Data Frame Structure

A data frame consists of 10 bytes:

- 2 start bytes (AAh followed by FFh)
- 2 data bytes (DATA16 – most significant byte first)
- 2 inverted data bytes (/DATA16 - most significant byte first)
- 4 all-Hi bytes

The Master should send AAh (55h in case of inverting transistor) followed by 9 bytes FFh. The Slave will answer with two bytes FFh followed by 4 data bytes and 4 bytes FFh.

Protocol description – Serial Peripheral Interface (SPI) (Fortsetzung)
Timing

There are no timing limits for frames: a frame transmission could be initiated at any time. There is no interframe time defined.

Data Structure

The DATA16 could be a valid angle or an error condition. The two meanings are distinguished by the LSB.

DATA16: Angle A[13:0] with (Angle Span)/2¹⁴

Most Significant Byte							Least Significant Byte								
MSB						LSB	MSB							LSB	
A13	A12	A11	A10	A9	A8	A7	A6	A5	A4	A3	A2	A1	A0	0	1

DATA16: Error

Most Significant Byte							Least Significant Byte								
MSB						LSB	MSB							LSB	
E15	E14	E13	E12	E11	E10	E9	E8	E7	E6	E5	E4	E3	E2	E1	E0

DATA16: Error

BIT	Name	Description
E0	0	
E1	1	
E2	F_ADCMONITOR	ADC Failure
E3	F_ADCSATURA	ADC Saturation (Electrical failure or field too strong)
E4	F_RGTOOLOW	Analog Gain Below Trimmed Threshold (Likely reason: field too weak)
E5	F_MAGTOOLOW	Magnetic Field Too Weak
E6	F_MAGTOOHIGH	Magnetic Field Too Strong
E7	F_RGTOOHIGH	Analog Gain Above Trimmed Threshold (Likely reason: field too strong)
E8	F_FGCLAMP	Never occurring in serial protocol
E9	F_ROCLAMP	Analog Chain Rough Offset Compensation: Clipping
E10	F_MT7V	Device Supply VDD Greater than 7V
E11	-	
E12	-	
E13	-	
E14	F_DACMONITOR	Never occurring in serial protocol
E15	-	

Angle Calculation

All communication timing is independent (asynchronous) of the angle data processing. The angle is calculated continuously by the Slave every 350 μs at most. The last angle calculated is hold to be read by the Master at any time. Only valid angles are transferred by the Slave, because any internal failure of the Slave will lead to a soft reset.

Error Handling

In case of any errors listed above, the Serial protocol will be initialized and the error condition can be read by the master. The slave will perform a soft reset once the error frame is sent. In case of any other errors (ROM CRC error, EEPROM CRC error, RAM check error, intelligent watchdog error...) the Slave's serial protocol is not initialized. The MOSI/MISO output will stay Hi-impedant (no error frames are sent).

Series HTI36 - singleturn, incremental output

Key features HTI36:

- Channels: A, B and index signal Z
- TTL or Open Collector electronics
- Maximum number of pulses per channel 1.024 (TTL), 20.000 pulses per revolution (option BZOC only)
- Option: ex works programmable number of pulses in pulse step width 1



Electrical data HTI25K – singleturn, incremental output

Output Signal	TTL	Open Collector
Number of pulses	1 to 1024 ppr	1 to 20.000 ppr
Limit frequency	100 kHz	250 kHz
Switch-on delay	20 ms	6.3 ms
Supply voltage	5 VDC ±10%	4.8 to 42 V
Power consumption (no load)	≤ 15 mA	≤ 24 mA (for 5 V input)
Output load	≥ 5 kOhm	
Max. pull-up voltage	-	42 VDC
Max. pull-up current	-	600 mA
Insulation voltage 1.)	1000 VAC @ 50 Hz, 1 min	
Insulation resistance 1.)	2 MOhm @ 500 VDC, 1 min	
MTTF (SN29500-2005-1)	473a	1000a

Output circuit HTI36 per channel

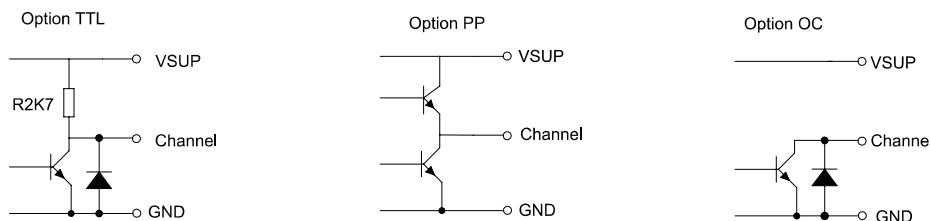

Connector types M12 (R) HTI36 – pin numbering

Type 2 (8 pole)

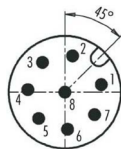

Type 3 (12 pole, special versions only)



The orientation of the connector relative to the encoder housing is not defined and differs from one encoder to the next. When using angled connectors in combination with axial outlet, the orientation of the cable outlet is thus not defined.

If you need a defined orientation of the cable outlet, please choose our housings with radial cable outlet and use straight mating connectors.

Order Code HTI36 - solid or hollow shaft, singleturn, incremental signal output

Description	Selection: standard= black/bold , possible options= <i>grey/italic</i>							
Series HTI36	HTI36							
Shaft type: Solid shaft Hollow shaft with screw fixation <i>Hollow shaft with clamp fixation</i>		S H <i>HK</i>						
Shaft diameter, shaft length: Shaft diameter Ø 6 mm <i>Shaft diameter Ø 8 mm</i> <i>Shaft diameter Ø 6.35 mm</i> <i>User-defined shaft diameter [mm]</i> <small>Ø ≤8 mm in connection with option S Ø ≤10 mm in connection with option H or HK Ø ≤12 mm exclusively in connection with option H</small>			6 <i>8</i> <i>6,35</i> <i>X</i>					
Multiplication symbol [x]: For solid shaft (S) For Hollow shaft H or HK				X <i>-</i>				
Visible shaft length: Shaft length 16.5 mm for solid shaft (S) shaft length for hollow shafts H or HK <i>User-defined shaft length for solid shaft S [mm]</i>					16,5 <i>-</i> <i>XX</i>			
Number of pulses (pulses per revolution) <i>100</i> 360 <i>512</i> 1024 <i>User-defined number of pulses</i>						<i>100</i> 360 <i>512</i> 1024 <i>XXXX</i>		
Supply voltage / output signals: VSUP=5 V ± 10% / OUT=TTL A, B, Z VSUP=4.8 to 42 V / OUT=open collector A, B, Z							05BZTTL BZOC	
Shaft sealing: Without shaft sealing (IP65) <i>With shaft sealing (IP67)</i>							<i>-</i> <i>D</i>	
Electrical connection, cable length, position: 1 m round cable, axial 1 m round cable, radial Plug M12, axial Connector M12, radial <i>Round cable, customer-specific cable length [X,XX m], axial</i> <i>Round cable, customer-specific cable length [X,XX m], radial</i>								PG PGR M12 M12R <i>PG X,XX</i> <i>PGR X,XX</i>

Order example HTI36 - solid shaft, singleturn, incremental output

Requirements:
Solid shaft Ø 6.00 mm, Shaft length 16.5 mm, number of pulses 1024, VSUP=5 V/TTL output signal, no shaft sealing, round cable 1 m, cable outlet position axial (in dependency to the shaft)

Example for order code:
HTI36 S 6x16,5 1024 05BZTTL PG

General
Contents
Redundant
Voltage/Current
Analogue (HTA36)
PWM (HTP36)
Serial (HTS36)
Incremental (HTI36)
Multiturn HTA36 PM
Solid Shaft
Hollow shaft
Drawings
Mechanical Data
Accessories

Cable and pin assignment HTI36 – option PP, TTL, OC		
Function:	Option PG(R)	Option M12(R)
GND	black	PIN 1
VSUP	red	PIN 2
Z	yellow	PIN 3
B	orange	PIN 4
A	brown	PIN 5
-	green n/c	PIN 6 n/c
-	-	PIN 7 n/c
-	-	PIN 8 n/c

General
Contents
Redundant
Voltage/Current
Analogue (HTA36)
PWM (HTP36)
Serial (HTS36)
Incremental (HTI36)
Multiturn HTA36 PM
Hollow shaft
Solid Shaft
Drawings
Mechanical Data
Accessories

Signal details

Incremental signal output patterns:

A, B, Z (05BZTTL, 24BZPP)

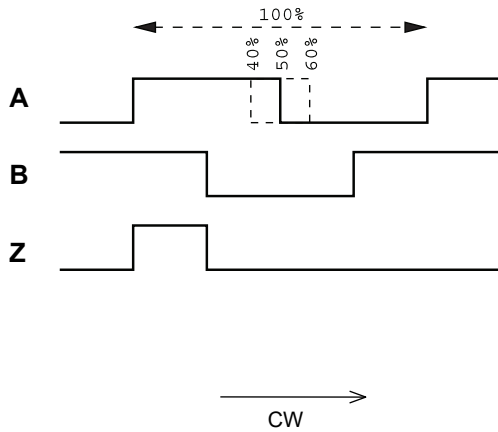

The percentage information describes the proportion of a pulse in dependency to the duration of one period

Option differential signal output (TTL N only)
A, A/, B, B/, Z, Z/

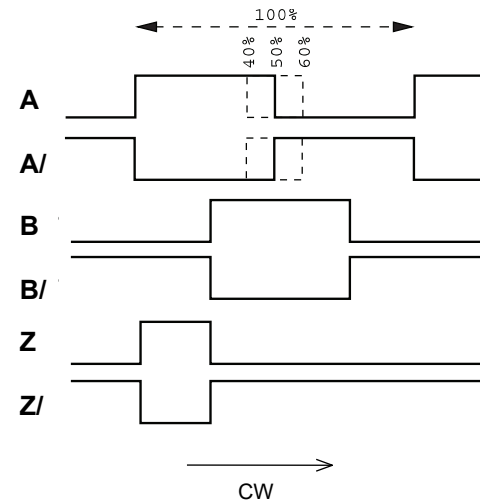

A, B, Z (Version BZOC)

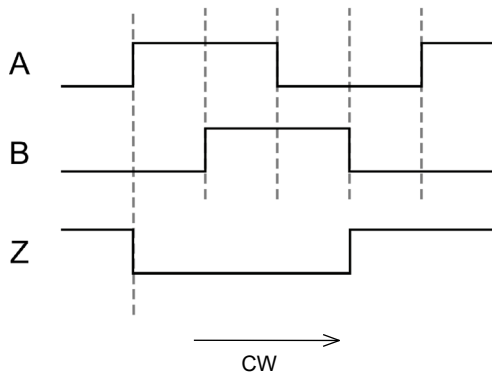

General
Contents
Redundant Voltage/Current Analogue (HTA36)
PWM (HTP36)
Serial (HTS36)
Incremental (HTI36)
Multiturn HTA36 PM
Hollow shaft Solid Shaft Drawings
Mechanical Data
Accessories

Series HTA36PM – multiturn/singleturn, programmable, analogue output, not redundant

Key features HTA36PM :

- Measuring range 10° to max. 72000° (200 shaft revolutions)
- Programmable by the user. Programmable are the sense of rotation (CW/CCW) and the effective electrical angle [°]
- Programmable up to 10.000 times
- Can also be used as a programmable singleturn rotary encoder
- Maximum rotation of the shaft in a voltage-free state without loss of the angle information +/-179°
- Factory programming (ex works): effective electrical angle of rotation 3600° (10 shaft revolutions), sense rotation CW
- Supply voltage: 9 to 30 VDC, 15 to 30 VDC
- Output signal: 4 to 20 mA, 0 to 5 V, 0 to 10 V

Electrical data HTA36PM – multiturn/singleturn, programmable, analogue output, not redundant

Effective electrical angle of rotation 1.)	0 to 10° - 0 to 72000° (max. 200 turns) Start point, endpoint and sense of rotation programmable by the customer. Ex works the angle is set to 3600°. For detecting absolute position >360° the sensor should not be turned more than ±179° without supply voltage.		
Independent linearity (best straight line) 1.)	±0.05% @ 3600°		
Absolute Linearity 1.)	±0.1% @ 3600°		
Output signal	0 to 5 V	0 to 10 V	4 to 20 mA
Resolution 1.)	12 Bit		
Update rate	3 ms		
Supply voltage	9 to 30 V	15 to 30 V	11 to 30 V
Power consumption (no load)	< 10 mA		< 14 mA
Output load	≥ 5 kOhm		≤ 500 Ohm
Insulation voltage 1.)	1000 VAC @ 50 Hz, 1 min		
Insulation resistance 1.)	2 MOhm @ 500 VDC, 1 min		
Max. number of programming cycles	10000		
MTTF (SN29500-2005-1)	224a		229a

1.) According IEC 60393

Signal output function (factory programming). Automatic function for inserting signal plateaus

The function represents the relationship between the zero degree marking on the rotary encoder housing in dependency to the 0° position of the shaft and the resulting output signal in the state of delivery, when turning the shaft clockwise (sense of rotation CW). The effective electrical angle of rotation is 3600° ex works. Before and after the linearly rising output signal for 3600° the HTA36PM integrates automatically signal plateaus for a rotation angle of each 180° .

The following example shows the output signal pattern when actuating the shaft in the delivery state for 11 revolutions clockwise (sense of rotation CW), starting at the 0° position:

1. 10 rotations of the shaft clockwise 0° to 3600°, linearly increasing output signal 0% to 100% FS
2. 1/2 rotation of the shaft 180° (3600° to 3780°) signal plateau 100% FS
3. 1/2 rotation of the shaft 180° (3780° to 3960°) signal plateau 0% FS

The drawing shows the signal-amplitude function for 0 to 10 V signal output



Order code HTA36PM – multiturn/singleturn, programmable, analogue output, not redundant

Description: User-programmable multiturn/singleturn rotary encoder. Programmable sense of rotation, effective electrical angle ex works: CW, 3600° (10 turns)	Selection: standard= black/bold , possible options= <i>grey/italic</i>						
Series HTA36PM	HTA36						
Shaft type: Solid shaft Hollow shaft with screw fixation <i>Option: with clamp fixation</i>		S H HK					
Shaft diameter, shaft length: Shaft diameter Ø 6 mm <i>Shaft diameter Ø 8 mm</i> <i>Shaft diameter Ø 6.35 mm</i> <i>User-defined shaft diameter [mm]</i> <small>Ø ≤8 mm in connection with option S Ø ≤10 mm in connection with option H or HK Ø ≤12 mm exclusively in connection with option H</small>			6 <i>8</i> <i>6,35</i> <i>X</i>				
Multiplication symbol [x]: For solid shaft (S) For Hollow shaft H or HK				x -			
Visible shaft length: Shaft length 16.5 mm for solid shaft (S) Shaft length for hollow shafts H or HK <i>User-defined shaft length for solid shaft S [mm]</i>					16,5 - XX		
Supply voltage / Output signal: VSUP=24 V (11 to 30 V) / OUT=4 to 20 mA VSUP=24 V (9 to 30 V) / OUT=0 to 5 V VSUP=24 V (15 to 30 V) / OUT=0 to 10 V						2442 2405 2410	
Shaft sealing: Without shaft sealing IP65 <i>With shaft sealing (IP67)</i>						- D	
Electrical connection, cable length, position: 1 m round cable, axial 1 m round cable, radial Plug M12, axial Connector M12, radial <i>Round cable, customer-specific cable length [X,XX m], axial</i> <i>Round cable, customer-specific cable length [X,XX m], radial</i>							PG PGR M12 M12R <i>PG X,XX</i> <i>PGR X,XX</i>

Order example HTA36PM S – solid shaft, multiturn/singleturn, programmable, analogue output, not redundant

Requirements:
Shaft Ø 6.00 mm, shaft length 16.5 mm, VSUP=24 V / OUT=0 to 5 V, sense of rotation ex works CW (programmable by customer), effective electrical angle ex works 3600° (programmable by the customer), no shaft sealing, round cable 1 m, cable outlet position axial (in dependency to the shaft)

Example for order code: HTA36PM S 6x16,5 2405 PG

Order example HTA36PM H – hollow shaft, multiturn/singleturn, programmable, analogue output, not redundant

Requirements:
Hollow shaft Ø 6.00 mm, fixation of the applications side shaft in the hollow shaft by means of grub screws, VSUP=24 V / OUT=4 to 20 mA, sense of rotation ex works CW (programmable by customer), effective electrical angle ex works 3600° (programmable by the customer), no shaft sealing, round cable 1 m, cable outlet position axial (in dependency to the shaft)

Example for order code: HTA36PM H 6 2442 PG

General
Contents
Redundant
Voltage/Current
Analogue (HTA36)
PWM (HTP36)
Serial (HTS36)
Incremental (HTI36)
Multiturn HTA36 PM
Solid Shaft
Drawings
Hollow shaft
Mechanical Data
Accessories

Order example HTA36PM programmer
Key features HTA36PM programmer "PRO":

- For programming of the sense of rotation (CCW/CW)
- For programming of the effective electrical angle of rotation [°]

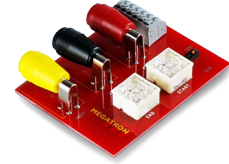
Order number:

135945

Order code:

Programmer Tool for series ETA25PM | HTAxxPM

Programming of HTA36PM – multiturn/singleturn, programmable, analogue output

 The programming guide is available for download on the MEGATRON web page <https://www.megatron.de/>

To program the HTA36PM rotary encoder either the following circuit must be built, or the programmer must be ordered from MEGATRON.

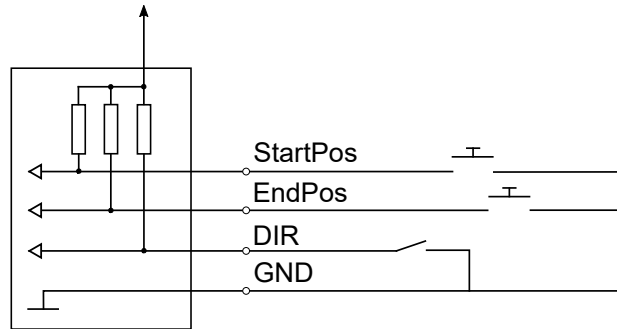
Cable and pin assignment HTA36PM – singleturn/multiturn, programmable, analogue output

Function:	Option PG(R):	Option M12(R)
GND	black	PIN 1
VSUP	red	PIN 2
OUT	brown	PIN 3
DIR	orange	PIN 4
START	yellow	PIN 5
END	green	PIN 6
-	-	PIN 7 n/c
-	-	PIN 8 n/c

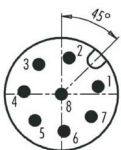
Connector types M12 (R) HTA36PM – pin numbering
Type 2 (8 pole)

The orientation of the connector relative to the encoder housing is not defined and differs from one encoder to the next. When using angled connectors in combination with axial outlet, the orientation of the cable outlet is thus not defined.

If you need a defined orientation of the cable outlet, please choose our housings with radial cable outlet and use straight mating connectors.

Drawings HTx36 S – solid shaft

HTx36 S (solid shaft), option M12R – M12 plug, radial orientation

Side view:

Front view:

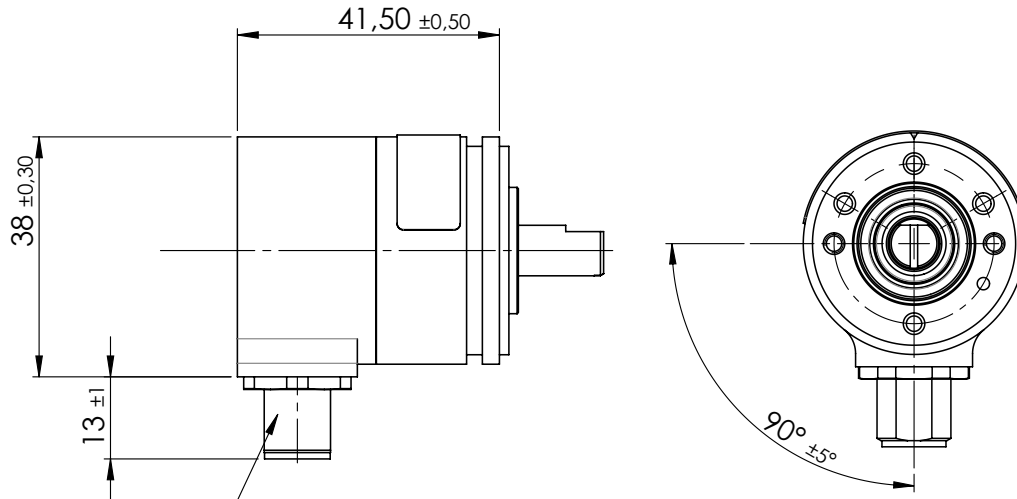

Binder male panel mount connector, range M12-A, 713 series or interoperable product

HTx36 S (solid shaft), option PG – cable gland, axial orientation incl. signal cable

Side view:

Front view:

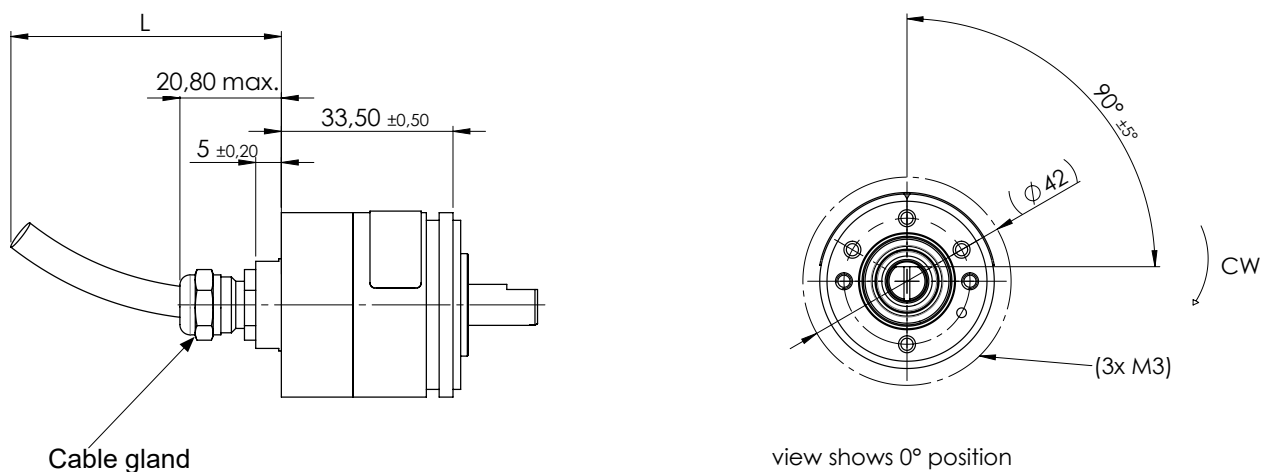

Cable gland

view shows 0° position

General
Contents
Redundant
Voltage/Current
Analogue (HTA36)
PWM (HTP36)
Serial (HTS36)
Incremental (HTI36)
Multiturn HTA36 PM
Solid Shaft
Hollow shaft
Drawings
Mechanical Data
Accessories

Drawings HTx36 S – solid shaft

HTx36 S option PG R – cable gland, radial orientation incl. signal cable

Front view:

Side view:

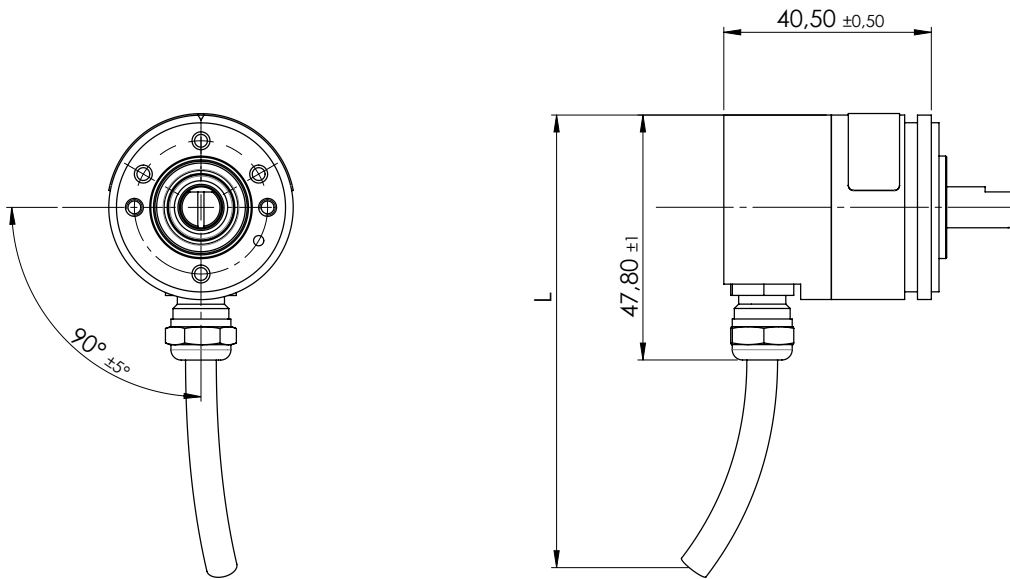

Ex works zero degree reference point (*), sense of rotation:

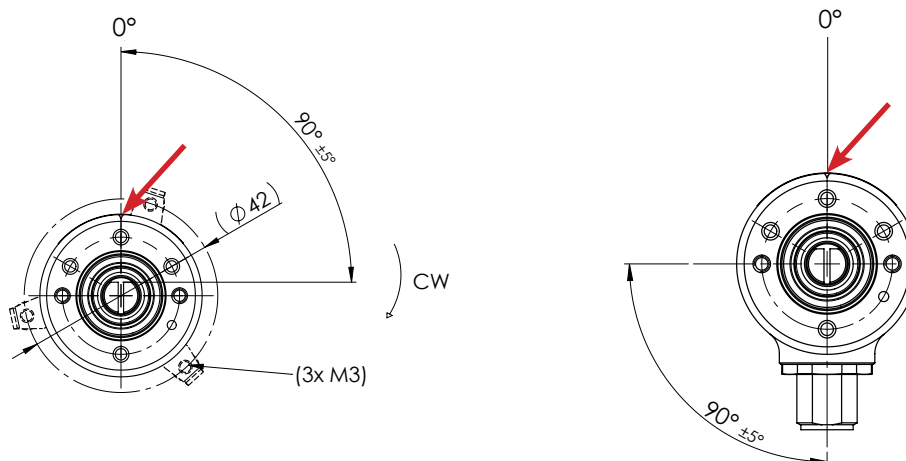

- (*) The drawings above shows the zero degree (0°) reference correlation for HTx36 S rotary encoders
- 0° position: If the shaft flattening is facing the groove marked with the red arrow (see drawing above), then the output signal is 0% full-scale.

General
Contents
Redundant Voltage/Current Analogue (HTA36)
PWM (HTP36)
Serial (HTS36)
Incremental (HTI36)
Multiturn HTA36 PM
Hollow shaft
Solid Shaft
Drawings
Mechanical Data
Accessories

Drawings HTx36 H – hollow shaft (screw fixation)

HTx36 H (hollow shaft, grub screw fixation), option M12 – M12 plug, axial orientation

Side view:

Binder male panel mount connector, range M12-A, 713 series or interoperable product

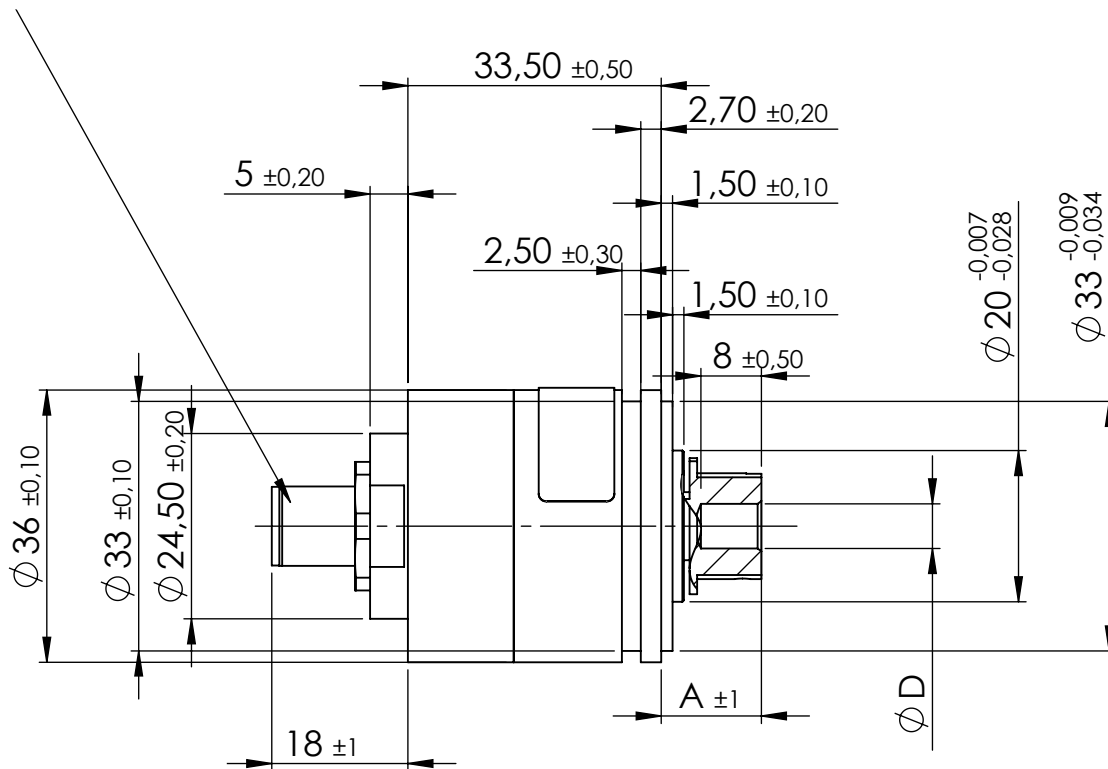

Front view:

View shows Product without Offset Bracket

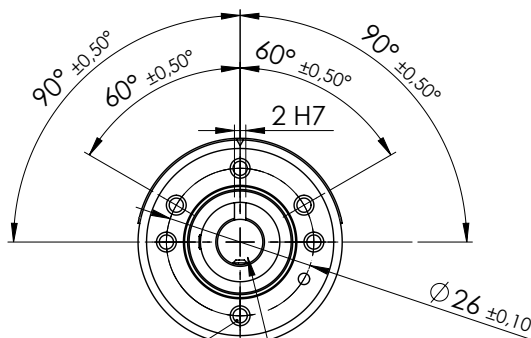

M3x0,5 6 ± 0,1 mm deep (6x)

tightening torque of M2,5 screws $SW1,3 \leq 0,5Nm$

Standard hollow shaft dimensions for HTx36 H with grub screw fixation

Hollow shaft length A	13.3 mm
Hollow shaft diameter D	6 mm 8 mm

Drawings HTx36 H – hollow shaft (screw fixation)

HTx36 H (hollow shaft screw fixation), option M12R – M12 plug, radial orientation

Side view:

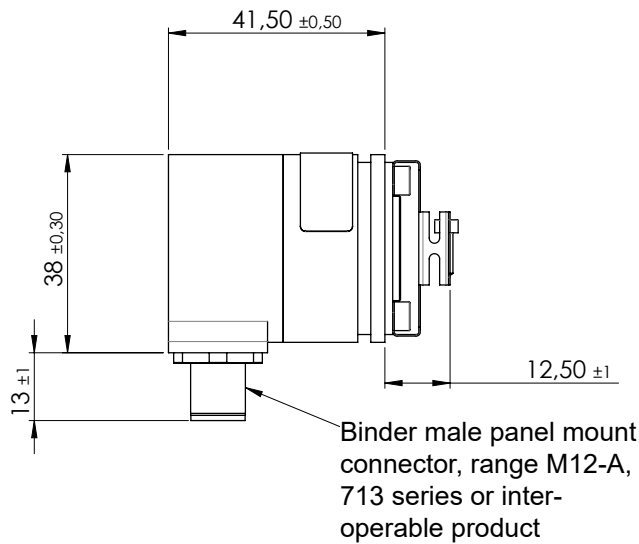

Front view:

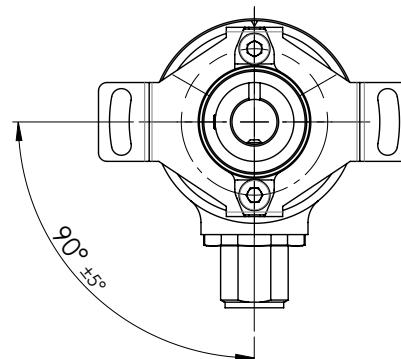

HTx36 H (hollow shaft, grub screw fixation), option PG – cable gland, axial orientation incl. signal cable

Side view:

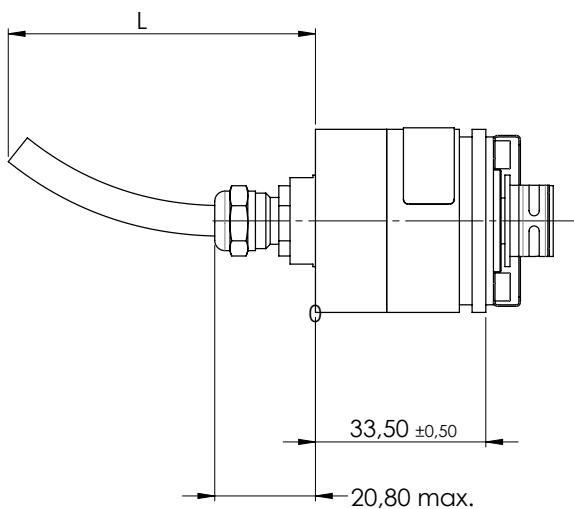

Front view:

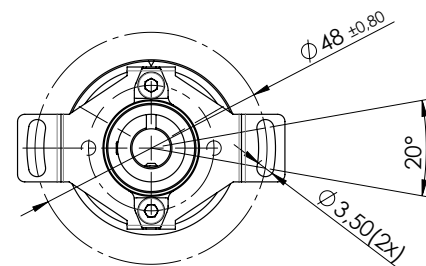

General
Contents
Redundant
Voltage/Current
Analogue (HTA36)
PWM (HTP36)
Serial (HTS36)
Incremental (HTI36)
Multiturn HTA36 PM
Solid Shaft
Hollow shaft
Drawings
Mechanical Data
Accessories

Drawings HTx36 H – hollow shaft (screw fixation)

HTx36 H (hollow shaft, grub screws fixation), option PG R – cable gland, radial orientation, incl. signal cable

Side view:

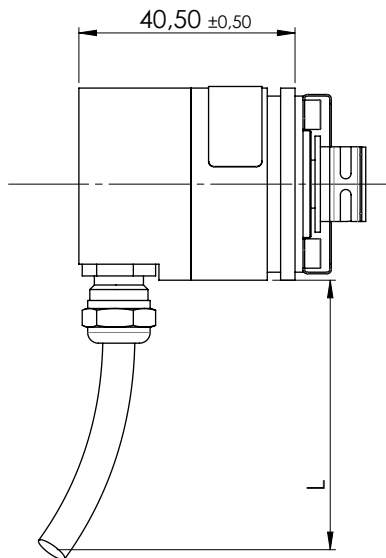

Front view:

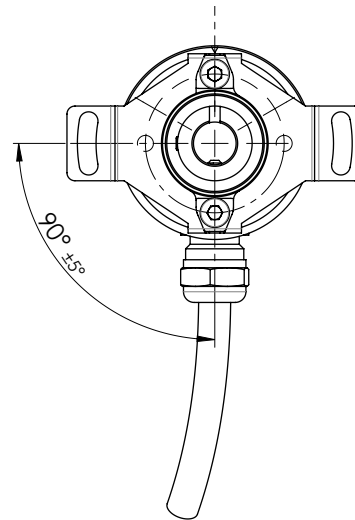

Ex works 0° position (*), sense of rotation:

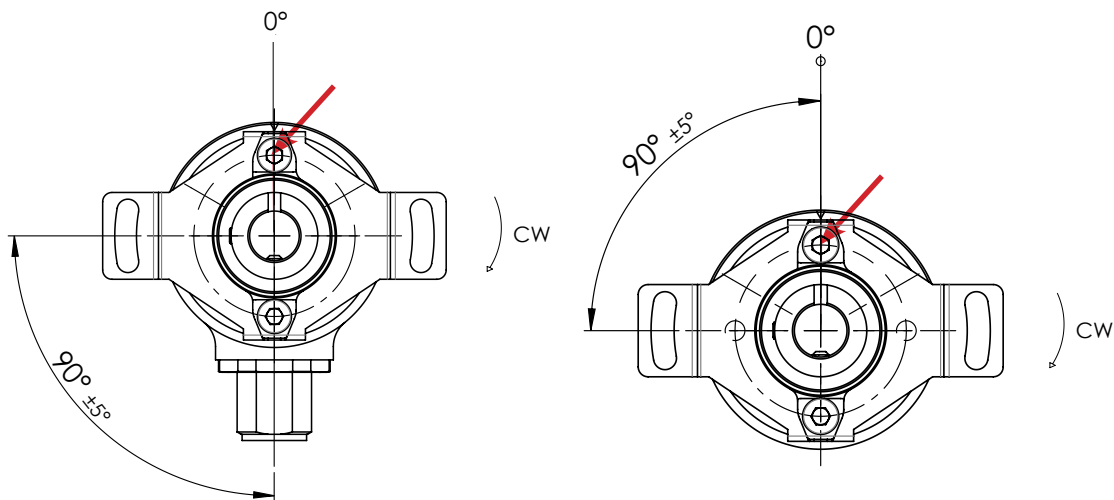

(*) The drawings above shows the zero degree (0°) reference
 If the shaft slot is in a line with the groove in the encoder housing (groove is marked with a red arrow) then the output signal is 0% full-scale.

General
Contents
Redundant Voltage/Current Analogue (HTA36)
PWM (HTP36)
Serial (HTS36)
Incremental (HTI36)
Multiturn HTA36 PM
Solid Shaft Drawings
Hollow shaft Drawings
Mechanical Data
Accessories

Drawings HTx36 HK – hollow shaft with clamp fixation

HTx36 HK (hollow shaft, clamp fixation), option M12 – M12 plug, axial orientation

Side view:

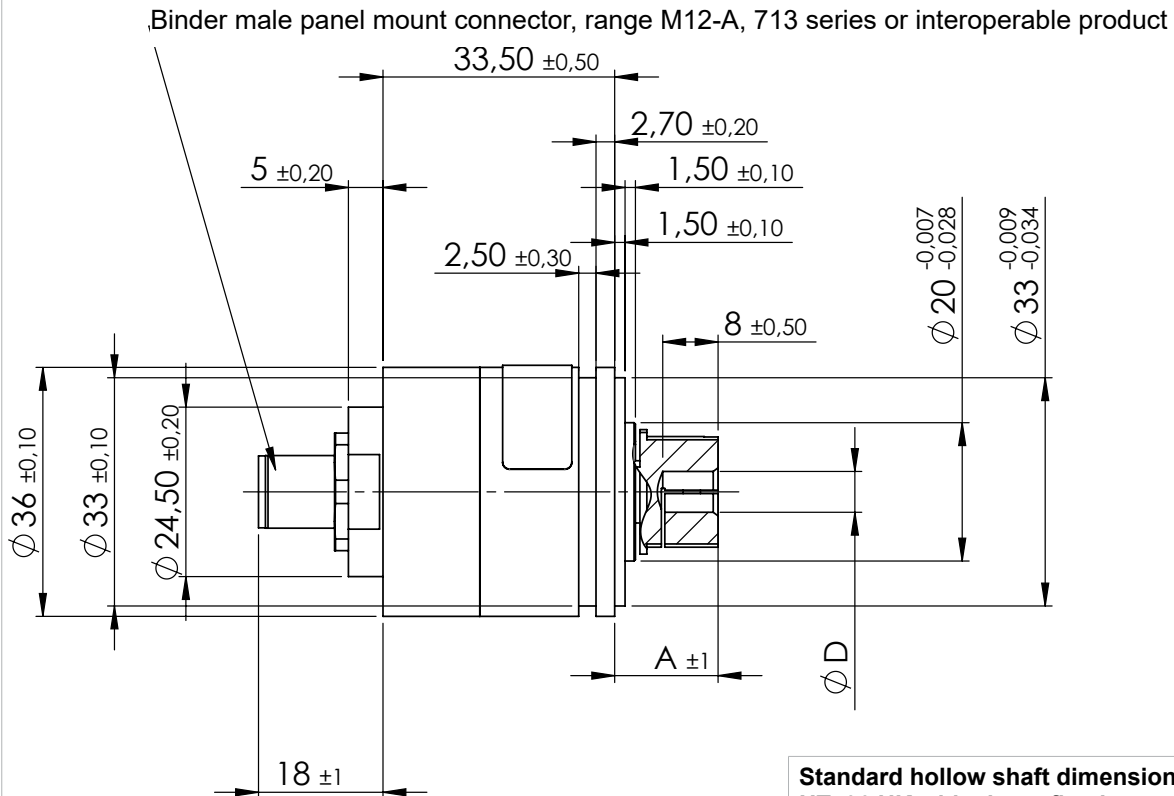

Standard hollow shaft dimensions for HTx36 HK with clamp fixation

Hollow shaft length A	15 mm
Hollow shaft diameter D	6 mm 8 mm

Front view:

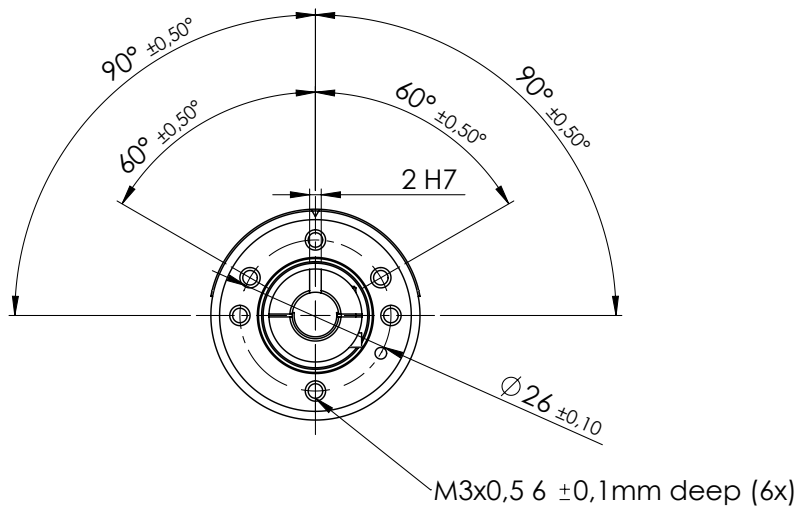

Drawings HTx36 HK – hollow shaft with clamp fixation

HTx36 HK hollow shaft, clamp fixation, option M12R – M12 plug, radial orientation

Side view:

Front view:

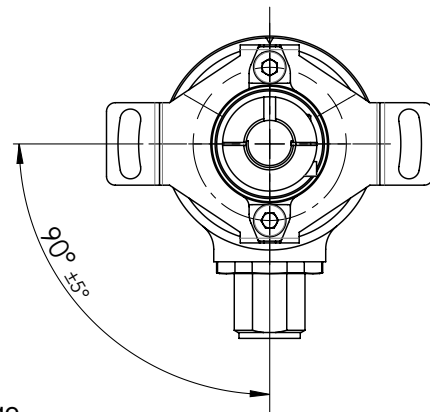
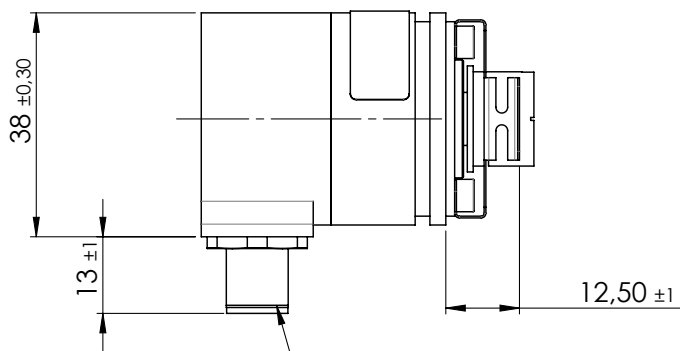

Binder male panel mount connector, range M12-A, 713 series or interoperable product

view shows connector orientation

HTx36 HK hollow shaft, clamp fixation, option PG – cable gland, axial orientation, incl. signal cable

Side view:

Front view:

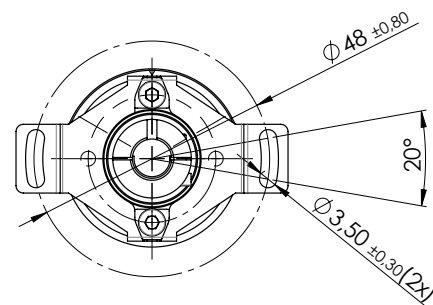
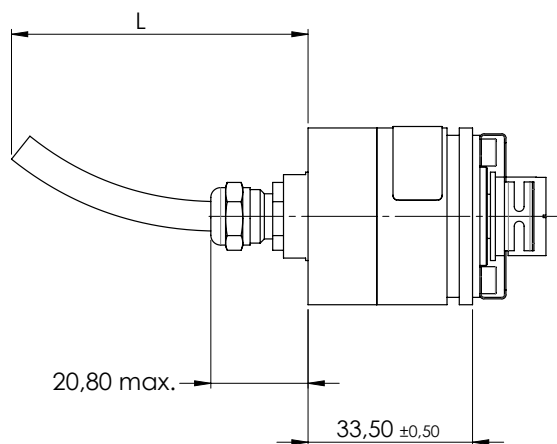

General
Contents
Redundant Voltage/Current Analogue (HTA36)
PWM (HTP36)
Serial (HTS36)
Incremental (HTI36)
Multiturn HTA36 PM
Solid Shaft
Hollow shaft
Drawings
Mechanical Data
Accessories

Drawings HTx36 HK – hollow shaft with clamp fixation

HTx36 HK with hollow shaft, clamp fixation), option PGR – cable gland, radial orientation, incl. signal cable

Side view:

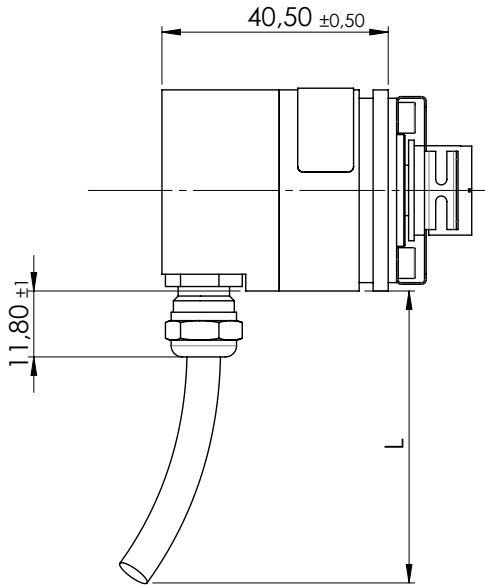

Front view:

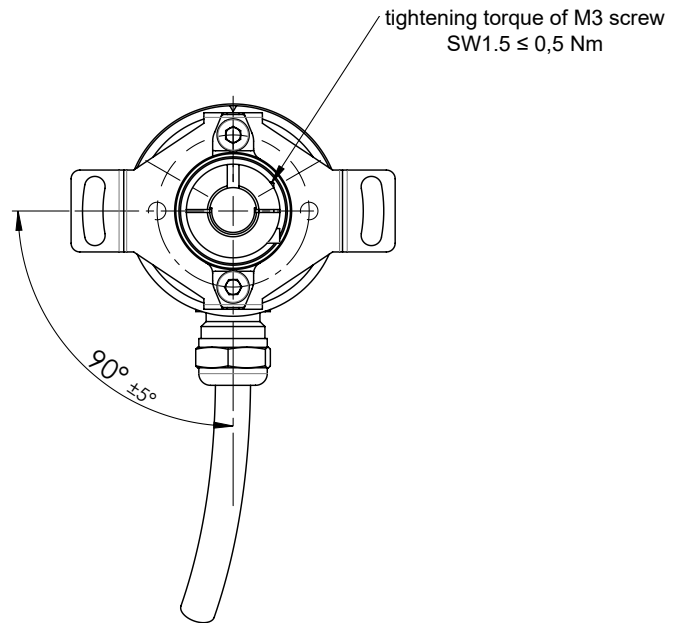

Ex works 0° position (*), sense of rotation:

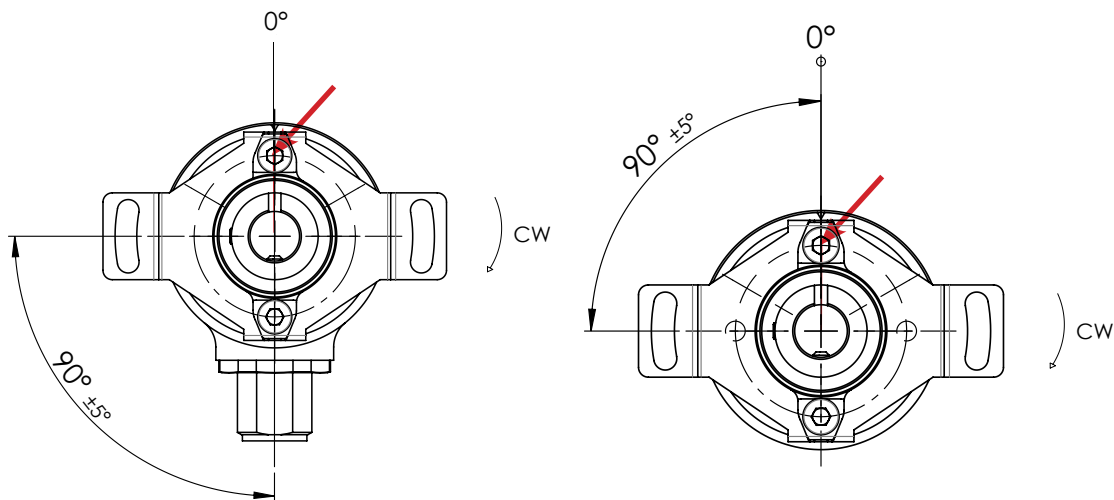

(* The drawings above shows the zero degree (0°) position
 If the shaft slot is in a line with the groove in the encoder housing (groove is marked with a red arrow) then the output signal is 0% full-scale.

General
Contents
Redundant
Voltage/Current
Analogue (HTA36)
PWM (HTP36)
Serial (HTS36)
Incremental (HTI36)
Multiturn HTA36 PM
Solid Shaft
Hollow shaft
Drawings
Mechanical Data
Accessories

Cable specs for option PG(R) (round control cable)						
Option	Standard cable length L	Number of single strands (depends on electronics)	Cable sheath Ø or width	Single strands cross section	Allowed tolerance (L)	Minimum bending radius
PG PGR	Standard 1000 mm	3		AWG26	-20 mm to +40 mm	10 x D Ø (D = cable sheath diameter Ø)
		6				
		8				
		10		AWG28		
		12				
Cables without cable shield						

(*) Tolerances according IPC Association

Cable length tolerances – custom lengths	
Length L	Tolerance
≤ 0.3 m	+25 mm / -20 mm
> 0.3 m - 1.5 m	+40 mm / -20 mm
> 1.5 m - 3 m	+100 mm / -40 mm
> 3 m - 7.5 m	+150 mm / -60 mm
Wire harness length measured from sensor face including connector. Minimum cable length: 0.08 m (for round cable). Please contact us for lengths > 3 m regarding handling and packaging.	

General
Contents
Redundant
Voltage/Current
Analogue (HTA36)
PWM (HTP36)
Serial (HTS36)
Incremental (HTI36)
Multiturn HTA36 PM
Solid Shaft
Hollow shaft
Drawings
Mechanical Data
Accessories

Mechanical and environmental data, miscellaneous – Family HTx36	
Shaft type	Solid shaft (HTx36 S) or hollow shaft (HTx36 H)
Mechanical angle of rotation 1.)	Endless
Lifetime (HTx36 S – solid shaft encoders) 2.)	@100 % of max. permissible radial shaft load >1.4x10E8 shaft revolutions @80 % of max. permissible radial shaft load >2x10E9 shaft revolution @20 % of max. permissible radial shaft load >1.7x10E10 shaft revolutions For option D (shaft sealing), the denseness is up to 1E6 shaft revolutions ensured
Bearing	2 pcs. groove ball bearings type 2RS
Max. operational speed (with shaft sealing)	12.000 rpm
Operational torque: (@ room temperature and 10 rev/min)	Solid shaft: ▪ Standard IP65: ≤ 0.3 Ncm ▪ With option D IP67: ≤ 2 Ncm Hollow shaft: ▪ Standard IP65: ≤ 0.5 Ncm ▪ With option D IP67: ≤ 2 Ncm
Operating temperature range	Option M12 (plug) ▪ -30 to +85°C Option PG (cable gland incl. cable) ▪ -30 to +85°C cable fixed ▪ -10 to +85°C cable in movement
Storage temperature range	-30 to +105 °C
Protection grade (IEC 60529) front side	From shaft side: ▪ Standard IP65 ▪ With option D IP67
Protection grade (IEC 60529) rear side	IP68 (cable ends excluded)
Vibration (DIN EN 60068-2-6)	±1.5 mm / 30 g / 10 to 2000 Hz / 16 frequency cycles (3x4 h)
Shock (DIN EN 60068-2-27)	100 g / 6 ms / half sine (3x6 shocks)
Housing diameter	Ø 36 mm
Housing depth	In dependency to the electrical connection position ▪ axial 33.5 mm ▪ radial 40.5 mm
Shaft diameter	Shaft diameter solid shaft: Standard: shaft diameter Ø 6 mm, Ø 8 mm Shaft diameter Ø 6.35 mm Option User-defined shaft diameter [mm] Ø ≤8 mm in connection with option S Ø ≤10 mm in connection with option H or HK Ø ≤12 mm exclusively in connection with option HK
Max. radial load (HTx36E S)	80 N (load point 80% in dependency to the visible standard shaft length)
Max. axial load	50 N (axial application of force onto the shaft end)
Mass (circa)	HTx36 with Plug M12(R) and: ▪ Solid shaft: axial 98 g, radial 90 g ▪ Hollow shaft: axial 102 g, radial 104 g HTx36 with cable gland and 1 m signal cable PG(R) and: ▪ Solid shaft: axial 133 g, radial 123 g ▪ Hollow shaft, axial 140 g, radial 133 g

1.) According IEC 60393

2.) Determined by climatic conditions according to IEC 68-1, para. 5.3.1 without load collectives

Mechanical and environmental data, miscellaneous – Family HTx36

Connection type	<p>Standard:</p> <ul style="list-style-type: none"> Cable gland stainless steel M12, axial, shielded round cable, 1 m, AWG26, PVC sheath, cable endings tinned <p>Option:</p> <ul style="list-style-type: none"> Plug M12, axial or radial
Connection position	Axial or radial
Sensor mounting	<p>Sensor mounting possibilities for solid shaft rotary encoders HTx36 S:</p> <ul style="list-style-type: none"> Via threaded holes integrated in the sensors head by use of stainless steel screws M3x0.5 Via synchro flange with optional available servo mount fixing nails SFN1 incl. screws M3 x 0.5 from MEGATRON <p>Sensor mounting for hollow shaft rotary encoders HTx36 H(K):</p> <ul style="list-style-type: none"> Using the ex work mounted torque bracket on the rotary encoder (spring plate) by means of 2 pcs of M3 screws
Fastening parts included in delivery	<p>None</p> <ul style="list-style-type: none"> For fastening the rotary encoder by means of servo mount fixing nails SFN1 – available from MEGATRON as accessory For options M12 (R), the M12 plug is not part of the scope of delivery. M12 plugs also incl. signal cable available as accessory from MEGATRON
Fastening torque per screw for fastening of the rotary encoder	<p>≤ 0.6 Nm (M3 screw)</p> <p>For screw securing, the use of a medium-strength thread securing adhesive is recommended</p>
Maximum tightening torque for grub screw for fixation of the shaft, only HTx36 H	≤ 0.5 Nm (wrench size M2.5 grub screw)
Maximum tightening torque for grub screw for fixation of the shaft, only HTx36 HK	≤ 0.5 Nm (wrench size M1.5 grub screw)
Material shaft	Stainless steel
Material housing	Aluminium
Material cable gland M12	Stainless steel

Immunity / Electrostatic Discharge / REACH / RoHS

EN 61000-4-3 RF sine wave	Class A
EN 61000-4-6 Conducted sine wave	Class A
EN 61000-4-8 Power frequency magnetic fields	Class A
EN 61000-4-2 ESD	Class B
REACH Regulation (EC) 1907/2006 including the SVHC list	
RoHS Directive 2011/65/EU	

General
Contents
Redundant
Voltage/Current
Analogue (HTA36)
PWM (HTP36)
Serial (HTS36)
Incremental (HTI36)
Multiturn HTA36 PM
Solid Shaft
Hollow shaft
Drawings
Mechanical Data
Accessories

Order Code – Full Overview

>>Please refer to the series sections for details and valid selection criteria

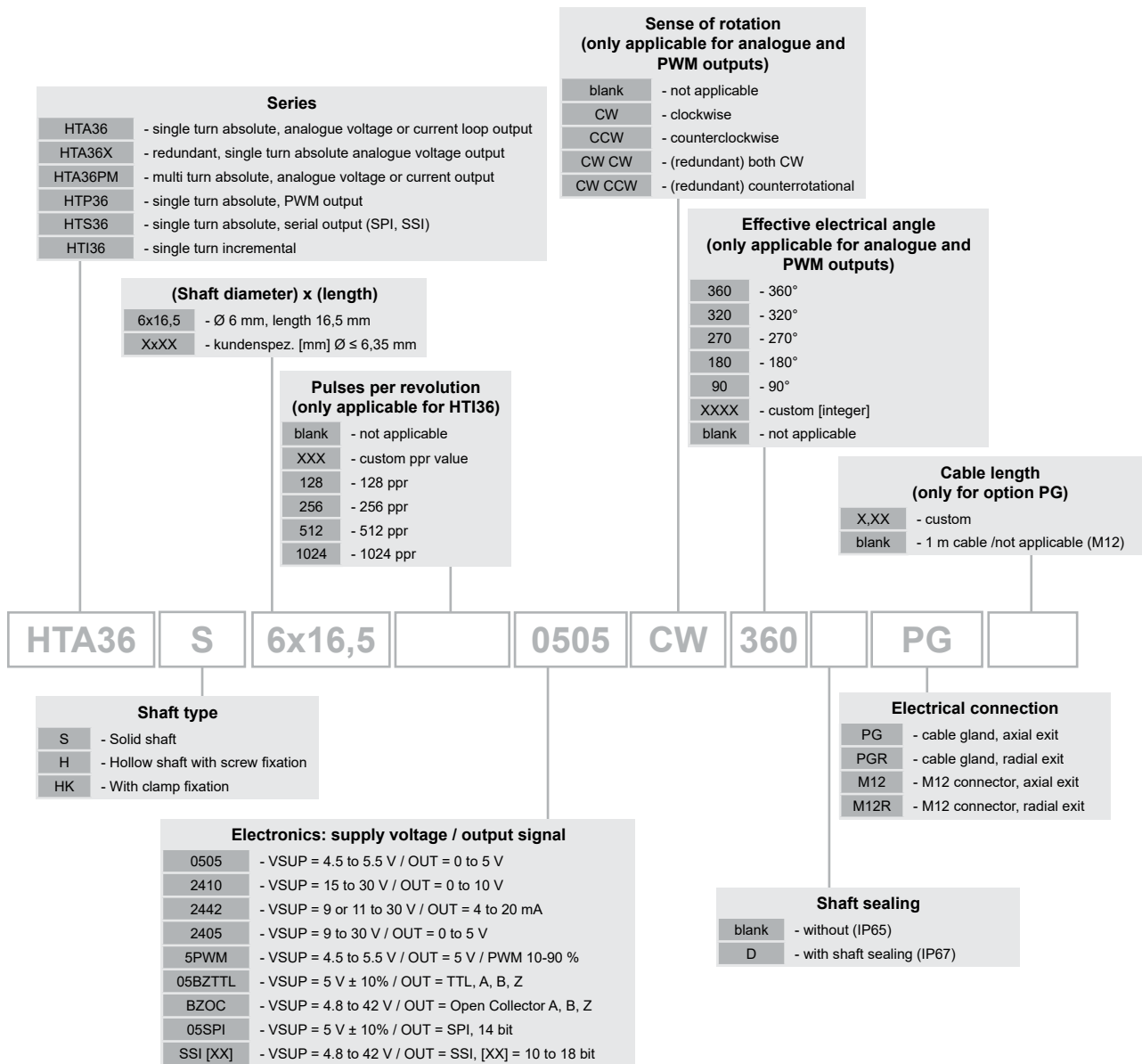

General
Contents
Voltage/Current
Redundant
Analogue (HTA36)
PWM (HTP36)
Serial (HTS36)
Incremental (HTI36)
Multiturn HTA36 PM
Solid Shaft
Hollow shaft
Drawings
Mechanical Data
Accessories

Servomount fixing nails SFN for encoders with solid shaft

- Required for mounting the rotary encoder when using synchro flange
- Fastening the rotary encoder requires at least 3 pcs.
- Ideal for panel mounting of the rotary encoder so that no holes have to be drilled through the panel
- By rotating the rotary encoder housing around its own axis, synchro clamps allow a zero point alignment with an application-side shaft that is already coupled to the rotary encoder (0° position)
- Material: stainless steel



M12 plugs without or with cable for option M12(R)

- STE plug without cable
- STK plug with cable



STE



STK

Shaft couplings for encoders with solid shaft

- Connect two shafts, even with different diameters
- Absorb larger angular and radial deviations
- Have a low inertia
- Do not cause a change in the transmission speed
- Damp torsional vibrations
- Serves as mechanical protection against oversized pairs of forces
- Made of plastic (also with metal hubs) act electrically and heat insulating



Counter ICs for HTI36 (incremental encoders)

- LS7083 in DIP or SOIC form factor, generates from incremental-signals quadrature-signals
- LS7166 24-Bit counter IC



LS7083/4N-S



LS7166



LS7083/4N

Programmer "PRO" for multiturn encoder HTA36PM

- For programming of the sense of rotation (CCW/CW)
- For programming of the effective electrical angle of rotation [°]

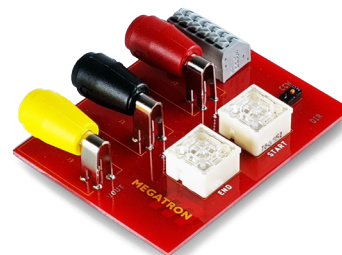

General
Contents
Redundant Voltage/Current Analogue (HTA36)
PWM (HTP36)
Serial (HTS36)
Incremental (HTI36)
Multiturn HTA36 PM
Hollow shaft Solid Shaft Drawings
Mechanical Data
Accessories