

**Series HTS25K – singleturn, digital output**
**Key features HTS25K:**

- SPI interface with 14 bit resolution and 5 V input voltage  
Attention: Signal transmission only possible via short signal lines
- SSI interface with 10-18 bit resolution and wide input range (4.8 to 42 V)

**Electrical data HTS25K – singleturn, digital output**

Output signal	SPI	SSI
Effective electrical angle of rotation 1.)	360°	
Independent linearity (best straight line) 1.)	±0,3% @ 360°	please contact us
Resolution	14 Bit	10-18 Bit
Update rate	200 µs	18 µs
Supply voltage	5 VDC ±10 %	4.8 to 42 V
Power consumption (no load)	≤ 12 mA	≤ 24 mA (for 5 V input)
Insulation voltage 1.)	1000 VAC @ 50 Hz, 1 min	
Insulation resistance 1.)	2 MOhm @ 500 VDC, 1 min	
MTTF (SN29500-2005-1)	2046a	800a

1.) According IEC 60393

**For details on zero point definition and output programming see page 29.**

Order Code HTS25K – singleturn, digital output				
<b>Description</b>	Selection: standard= <b>black/bold</b> , possible options= <i>grey/italic</i>			
<b>Series</b>	<b>HTS25K</b>			
<b>Supply voltage / output signal:</b> 4,8 to 42 V / SSI, 16 Bit resolution <i>4,8 to 42 V / SSI, custom resolution 10 to 18 bit</i> 5 VDC ± 10% / SPI (14 Bit)		<b>SSI 16</b> <i>SSI [10-18]</i> <b>05SPI</b>		
<b>Electrical connection, cable length:</b> 1 m round cable, axial 1 m round cable, radial <b>Connector M8, radial</b> <i>Connector M8, axial*</i> <i>Round cable, customer-specific cable length [X,XX m], axial</i> <i>Round cable, customer-specific cable length [X,XX m], radial</i>			<b>PG</b> <b>PGR</b> <b>M8R</b> <i>M8</i> <i>PGX,XX</i> <i>PGRX,XX</i>	
<b>Installation variant/drilling pattern:</b> <b>Variant S</b> (Pins for exact alignment optional and not included) <b>Variant P</b> (pins pre-installed on the rotary encoder for precise alignment)				<b>S</b> <b>P</b>

\* M8 axial connector variant not available for SSI

Order example HTS25K – singleturn, digital output
<b>Requirement:</b> 14 Bit/5 VDC/SPI, round cable 1 m, radial exit, installation type S (drilling pattern S)
<b>Example for order code:</b> HTS25K 05SPI PGR S

Order example HTS25K – singleturn, serial output
<b>Requirements:</b> Electronics 16 Bit/4,8 to 42 VDC/SSI, round cable 1 m axial, installation type S (drilling pattern S)
<b>Example for order code:</b> HTS25K SSI 16 PG S

**Please be aware of limiting factors in the cable lengths / transmission limits of serial communication.  
Baud rate/clock frequency must be adjusted to avoid transmission problems.**

**Cable and pin assignment for option 05SPI**

Function:	Option PG(R), round signal cable	Option M8(R), 8 pin
VSUP	red	1
GND	black	2
CS, MOSI	yellow	3
CLK	green	4
DATA	orange	5
-	brown n/c	6 n/c
-	-	7 n/c
-	-	8 n/c

**Cable and pin assignment for option SSI**

Function:	Option PG(R), round signal cable	Option M8R, 8 pin
GND	black	1
VSUP	red	2
CLK+	brown	3
CLK-	orange	4
DATA+	yellow	5
DATA-	green	6
-	-	7 n/c
-	-	8 n/c

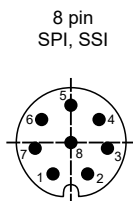
**Connector M8 (R) – pin assignment for 8-pin connectors**

Pin-Numbering of socket connector in the encoder housing

The orientation of the connector relative to the encoder housing is not defined and differs from one encoder to the next. When using angled connectors in combination with axial outlet, the orientation of the cable outlet is thus not defined.

If you need a defined orientation of the cable outlet, please choose our housings with radial cable outlet and use straight mating connectors.

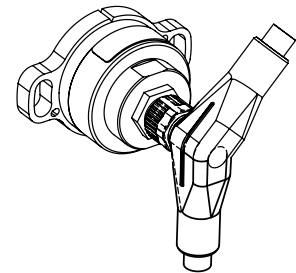

Orientation will vary when using angled connectors.

### Synchronous Serial Interface (SSI) - A simple yet robust interface

The synchronous serial interface (SSI) is a serial interface, i.e. the individual bits are transmitted in chronological order. The basis of data transmission is a shift register in which the encoder provides its current measured value. The rotary encoders function as so-called SSI slaves, because they only supply the values from the shift register at the DO (data out) output on receipt of a clock sequence sent out by the SSI master, the so-called "clock" signal (CLK). This clock signal is applied to the CLK input of the encoder. Both the clock signal and the data signal are transmitted differentially, which makes this type of data interface particularly robust against interference. In short, SSI enables the memory of a sensor to be read out reliably from an external source.

#### Data transmission

The SSI electronics of the encoder reacts to the first falling edge that arrives via the CLK line of the master, loads the current data into the register and transmits it bit by bit to the receiver with each rising edge of the clock. The composition of the transmitted information is not standardised and varies from manufacturer to manufacturer, sometimes even from product to product.

In MEGATRON's encoders, the position information is transmitted first (starting with the Most Significant Bit MSB, ending with the Least Significant Bit LSB). The maximum value of this information is limited by the number of bits transmitted. This is also the resolution of the measurement data. For example, a resolution of 10 bits corresponds to a number of  $2^{10} = 1024$  steps, which are divided over the angular range of  $360^\circ$ . Thus, after receiving the position information, it is easy to calculate back to the absolute angle, because each single step would correspond to  $360/1024 = 0.35^\circ$ .

The position information is followed by a bit sequence of status data that can be of great interest for the application. This includes, for example, the status of the electronics (readiness, correct supply voltage), but also whether the magnetic field acting on the Hall sensor is within the permissible limits (i.e. the distance of the magnet from the sensor). The last bit is the parity bit. This takes the values HIGH or LOW as required, so that the encoder always sends an even number of bits (even parity). The receiver, i.e. the SSI master, must be set to the total length of the transmitted information including the parity bit.

At the end of the process, the master usually does not send any further edges to the encoder via the CLK line. The encoder then waits for a time  $t_m$ , (retriggerable monoflop) since the last CLK edge and then updates the data in the shift register. This is therefore the minimum pause time between two consecutive clock sequences when the master requires new, updated measurement data. The exact protocol description of the HTS encoders follows on the next page

#### Ring shift

However, if clock edges continue to be sent, then the encoder will start transmitting the same data set repeatedly after a zero bit. This procedure is also called ringshift. This makes sense, for example, if the parity bit would be incorrect from the master's point of view, if the data is otherwise corrupt and a new transmission is therefore requested, or if a higher transmission reliability is generally desired by comparing multiple transmissions of the same data. With ring shift, the transmission is also terminated and the latest measurement data is only loaded into the register again when no more clock signals arrive at the encoder for a minimum time  $t_m$ .

#### Early stop

The transmission of the data can be interrupted by the master at any time, e.g. also after the 10th bit. Even then, the internal timer (monoflop) expires, causing the data in the register to be reloaded after the time  $t_m$ . In this way, for example, only a part of the encoder data can be read out (e.g. 10 of the available 16 bits, no status data at all) and a higher update rate can be achieved, as the remaining information is simply omitted.

#### Notes on cable length

The higher the transmission rate (clock rate), the smaller the realisable cable length with SSI. These are physical limits that are not limited by the sensor product itself. A simple blanket statement about the actual realisable length is not easily possible.

The cable length that can actually be realised in the application is influenced by the following factors:

- Quality and design of the cable (shielding, conductor cross-section, conductor resistance, twisted cores, etc.)
- Ambient conditions (sources of interference such as motors, etc.)

We explicitly refer to the RS-422 standard regarding cable lengths.

**Protocol description – Synchronous Serial Interface (SSI)**

The HTS25K SSI encoder provides a 10-bit to 18-bit absolute position output, while 16 bit is the standard (ex works) configuration. This means that the full rotation angle (360°) is divided into steps of the respective resolution (16 bits yields 65.536 steps of approx. 0.005 degrees).

Standard configuration (16 bit output) yields the following pulse train, consisting both of position and status data:



The data structure for any resolution is as follows:

Position data (10 to 18 bits)				Status (7-bit)							Parity 1 bit
MSB	MSB-1	...	LSB	RDY	MHI	MLO	OV	UV	MEM	TRK	PAR

Abbreviation	Description
MSB to LSB	n-bits position data, selectable from 10 to 18 bits ex works, standard is 16 bit
RDY	The encoder is ready (if value is HIGH).
MHI	This indicates that the magnet strength detected by the Hall chip is too strong. If this is consistently HIGH, change to a weaker magnet or increase the distance between the encoder and the magnet. The value for this alarm is displayed as 1.
MLO	This indicates that the magnet strength detected by the Hall chip is too weak. If this is consistently HIGH, change to a stronger magnet or decrease the distance between the encoder and the magnet. The value for this alarm is displayed as 1.
OV	Overvoltage error at Hall Chip if HIGH. Might indicate defective voltage regulator (encoder's internal regulator).
UV	Undervoltage error if HIGH. Might indicate too low input voltage or defective voltage regulator (encoder's internal regulator).
MEM	If HIGH, a memory corruption has occurred. Perform a power cycle to reload the memory.
TRK	This indicates that the angular error has exceeded 5° within 5 ms. When this value stays at HIGH, perform a power-cycle to re-initialize the sensor.
PAR	Parity is even

Data is transmitted according to the following timing diagram:

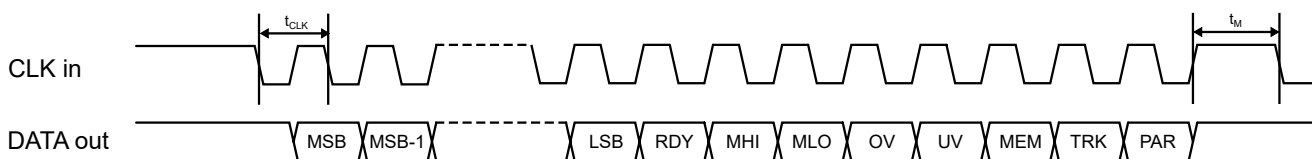

Symbol	Description	Min.	Typ.	Max.
$t_{CLK}$	Serial clock period	4 $\mu$ s		$t_{M/2}$
$t_M$	monoflop, time between two successive SSI reads		16.5 $\mu$ s	18 $\mu$ s

Data is latched on the first CLK falling edge and is transmitted on the next falling edge. Both signals are transmitted differentially and therefore have 2 connections (+/-) each. Data will be refreshed when the next monoflop ( $t_M$ ) expires. If another clock train is sent before this time expires, the same position data is output, and the data is separated by a single low bit:

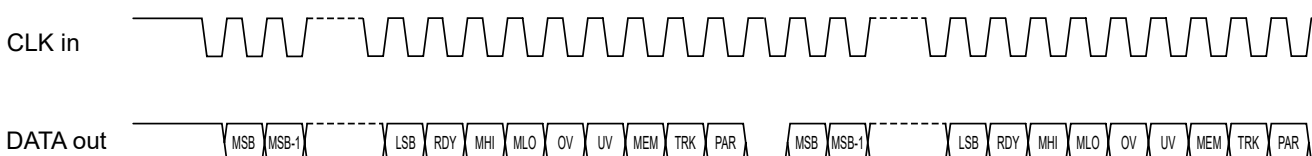

**Protocol description – Serial Peripheral Interface (SPI)**

**Introduction**

The encoder is configured as a Slave node. The serial protocol of the is a three wires protocol (/SS, SCLK, MOSI-MISO):

- /SS output is a 5 V tolerant digital input
- SCLK output is a 5 V tolerant digital input
- MOSI-MISO output is a 5 V tolerant open drain digital input/output

Basic knowledge of the standard SPI specification is required for the good understanding of the present section.

Even clock changes are used to sample the data. The positive going edge shifts a bit to the Slave's output stage and the negative going edge samples the bit at the Master's input stage.

**MOSI (Master Out Slave In)**

The Master sends a command to the Slave to get the angle information.

**MISO (Master In Slave Out)**

The MISO of the slave is an open-collector stage. Due to the capacitive load, a >1 kΩ pull-up is used for the recessive high level (in fast mode). Note that MOSI and MISO use the same physical wire of the ETS25.

**/SS (Slave Select)**

The /SS output enables a frame transfer. It allows a re-synchronization between Slave and Master in case of a communication error.

**Master Start-Up**

/SS, SCLK, MISO can be undefined during the Master start-up as long as the Slave is re-synchronized before the first frame transfer.

**Slave Start-Up**

The slave start-up (after power-up or an internal failure) takes 16 ms. Within this time /SS and SCLK is ignored by the Slave. The first frame can therefore be sent after 16 ms. MISO is Hi-Z (i.e. Hi-Impedance) until the Slave is selected by its /SS input. The encoder will cope with any signal from the Master while starting up.

**Timing**

To synchronize communication, the Master deactivates /SS high for at least t5 (1.5 ms). In this case, the Slave will be ready to receive a new frame. The Master can re-synchronize at any time, even in the middle of a byte transfer. Note: Any time shorter than t5 leads to an undefined frame state, because the Slave may or may not have seen /SS inactive.

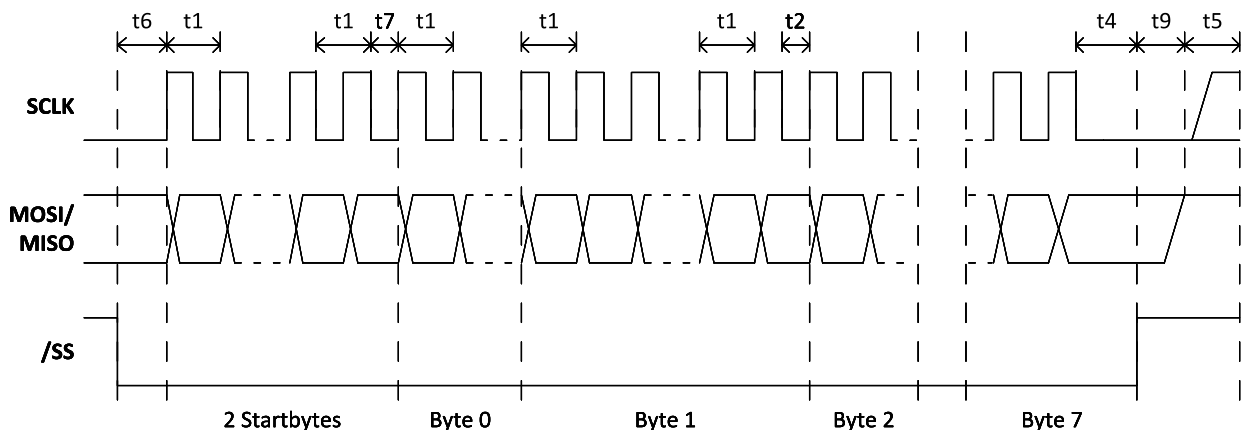

**Protocol description – Serial Peripheral Interface (SPI) (continuation)**
**Description Timings**

Timings	Min	Max	Remarks
t1	2.3 $\mu$ s	-	No capacitive load on MISO. t1 is the minimum clock period for any bits within a byte.
t2	12.5 $\mu$ s	-	t2 the minimum time between any other byte
t4	2.3 $\mu$ s	-	Time between last clock and /SS=high=chip de-selection
t5	300 $\mu$ s	-	Minimum /SS = Hi time where it's guaranteed that a frame re-synchronizations will be started
t5	0 $\mu$ s	-	Maximum /SS = Hi time where it's guaranteed that NO frame re-synchronizations will be started.
t6	2.3 $\mu$ s	-	The time t6 defines the minimum time between /SS = Lo and the first clock edge
t7	15 $\mu$ s	-	t7 is the minimum time between the StartByte and the Byte0
t9	-	< 1 $\mu$ s	Maximum time between /SS = Hi and MISO Bus HighImpedance
T <sub>Startup</sub>	-	< 10 ms	Minimum time between reset-inactive and any master signal change

**Slave Reset**

On internal soft failures the Slave resets after 1 second or after an (error) frame is sent. On internal hard failures the Slave resets itself. In that case, the Serial Protocol will not come up. The serial protocol link is enabled only after the completion of the first synchronization (the Master deactivates /SS for at least t5).

**Frame Layer**
**Command Device Mechanism**

Before each transmission of a data frame, the Master should send a byte AAh to enable a frame transfer. The latch point for the angle measurement is at the last clock before the first data frame byte.

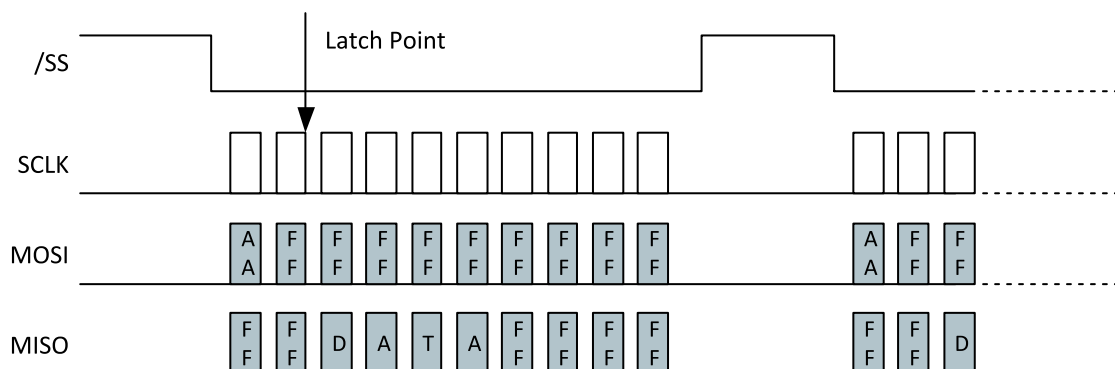
**Data Frame Structure**

A data frame consists of 10 bytes:

- 2 start bytes (AAh followed by FFh)
- 2 data bytes (DATA16 – most significant byte first)
- 2 inverted data bytes (/DATA16 - most significant byte first)
- 4 all-Hi bytes

The Master should send AAh (55h in case of inverting transistor) followed by 9 bytes FFh. The Slave will answer with two bytes FFh followed by 4 data bytes and 4 bytes FFh.

**Protocol description – Serial Peripheral Interface (SPI) (Fortsetzung)**
**Timing**

There are no timing limits for frames: a frame transmission could be initiated at any time. There is no interframe time defined.

**Data Structure**

The DATA16 could be a valid angle or an error condition. The two meanings are distinguished by the LSB.

**DATA16: Angle A[13:0] with (Angle Span)/2<sup>14</sup>**

Most Significant Byte							Least Significant Byte								
MSB						LSB	MSB								LSB
A13	A12	A11	A10	A9	A8	A7	A6	A5	A4	A3	A2	A1	A0	0	1

**DATA16: Error**

Most Significant Byte							Least Significant Byte								
MSB						LSB	MSB								LSB
E15	E14	E13	E12	E11	E10	E9	E8	E7	E6	E5	E4	E3	E2	E1	E0

**DATA16: Error**

BIT	Name	Description
E0	0	
E1	1	
E2	F_ADCMONITOR	ADC Failure
E3	F_ADCSATURA	ADC Saturation (Electrical failure or field too strong)
E4	F_RGTOOLOW	Analog Gain Below Trimmed Threshold (Likely reason: field too weak)
E5	F_MAGTOOLOW	Magnetic Field Too Weak
E6	F_MAGTOOHIGH	Magnetic Field Too Strong
E7	F_RGTOOHIGH	Analog Gain Above Trimmed Threshold (Likely reason: field too strong)
E8	F_FGCLAMP	Never occurring in serial protocol
E9	F_ROCLAMP	Analog Chain Rough Offset Compensation: Clipping
E10	F_MT7V	Device Supply VDD Greater than 7V
E11	-	
E12	-	
E13	-	
E14	F_DACMONITOR	Never occurring in serial protocol
E15	-	

**Angle Calculation**

All communication timing is independent (asynchronous) of the angle data processing. The angle is calculated continuously by the Slave every 350 µs at most. The last angle calculated is hold to be read by the Master at any time. Only valid angles are transferred by the Slave, because any internal failure of the Slave will lead to a soft reset.

**Error Handling**

In case of any errors listed above, the Serial protocol will be initialized and the error condition can be read by the master. The slave will perform a soft reset once the error frame is sent. In case of any other errors (ROM CRC error, EEPROM CRC error, RAM check error, intelligent watchdog error...) the Slave's serial protocol is not initialized. The MOSI/MISO output will stay Hi-impedant (no error frames are sent).



Drawings HTx25K – Drilling patterns S and P

**Dimensions Sensor head for Version with drilling pattern S**  
(pins optional, to be set by customer)

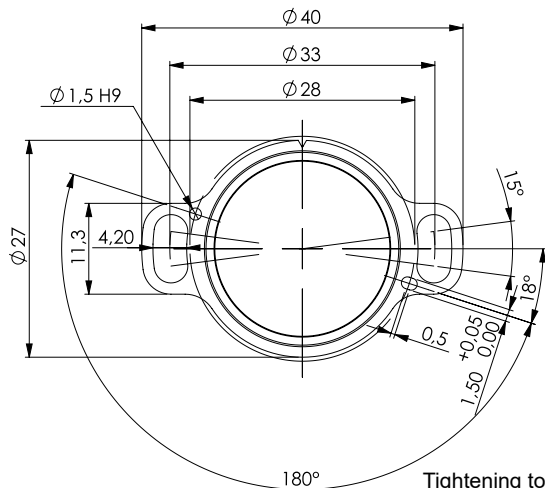

**Deviations of variant with drilling pattern P**  
(cylindrical pins part of the rotary encoder)

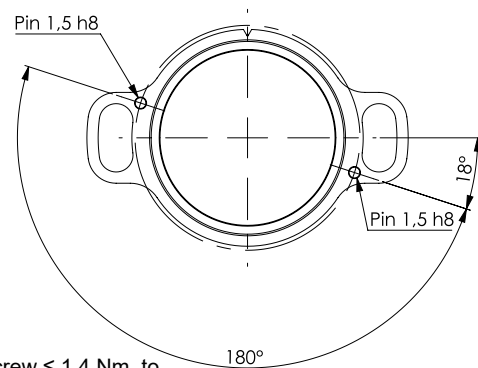

**Drilling pattern S**

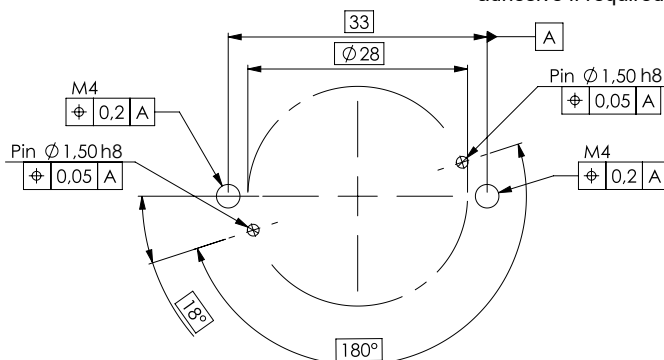

**Drilling pattern P**

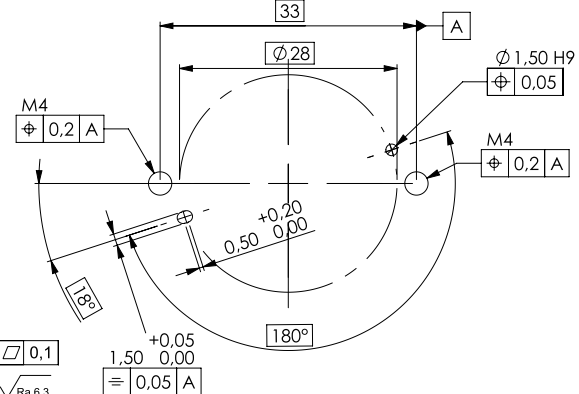

planarity of installation surface  $\square 0,1$   
roughness of installation surface  $\sqrt{Ra 6,3}$

All dimensions in mm

Accessories – Sealing ring



O-ring, part no. 133324  
DIN 3771-22x1-NBR 70

- For sealing between sensor front and mounting surface,
- Not included in delivery, please order separately

All dimensions in mm

Drawings HTx25K – Versions for drilling pattern S, magnet positioning

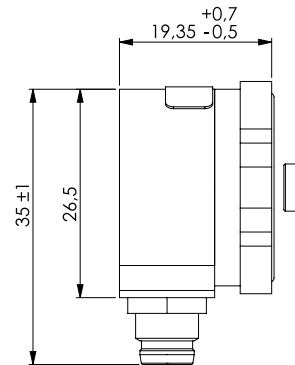
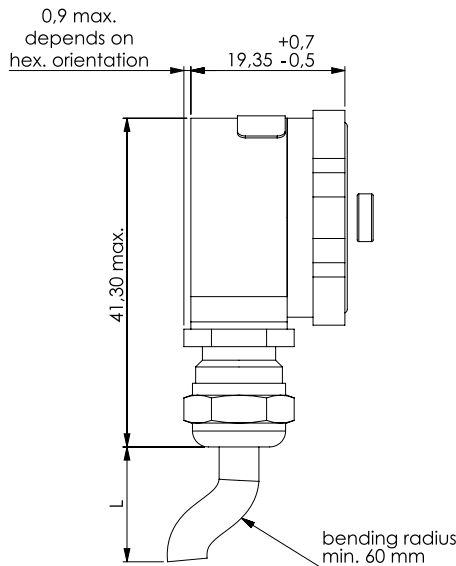
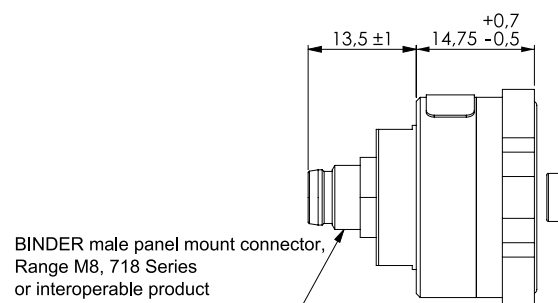
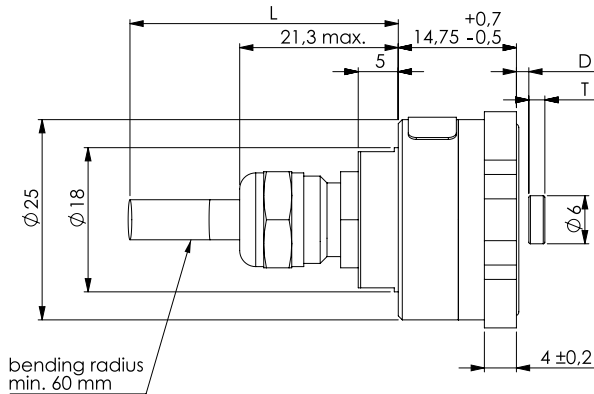

All dimensions in mm

Magnet selection and positioning for enclosed standard NdFeB magnets

**Important note:**

The correct mounting distance D as well as the correct positioning of the in relation to the central axis to the housing surface of the kiten-coder is mandatory for its correct function. The values below are not valid for other magnets (e. g. accessories).

Magnet thickness and distance from sensor surface		
Electronics	Thickness T of the magnet	Mounting distance D
Analogue singleturn not redundant, HTA25K, HTP25K, HTS25K (only SPI)	3 mm	1.50 +/- 0.15 mm
Serial, SPI, (HTS25K)	3 mm	1.50 +/- 0.15 mm
Serial, SSI, (HTS25K)	4 mm	0.50 +/- 0.15 mm
Analogue redundant, HTA25KX	2.5 mm	0.50 +/- 0.15 mm
Incremental, HTI25K	4 mm	0.50 +/- 0.15 mm
Analogue multi turn HTA25KPM	4 mm	1.00 +/- 0.15 mm

**Drawings HTx25K – Deviations for drilling pattern P**

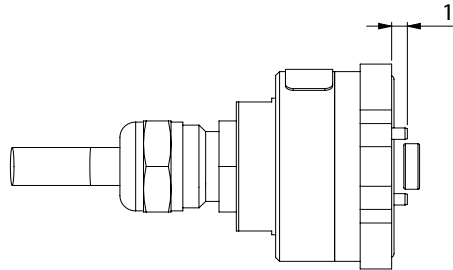

Pins/cylindrical pins are only pre-assembled if drilling hole pattern P is selected.  
Missing dimensions see drawings of the variants for hole pattern S.

**Drawings – Cable/connector exit direction for radial versions (M8R, PGR)**

view shows cable orientation

view shows connector position

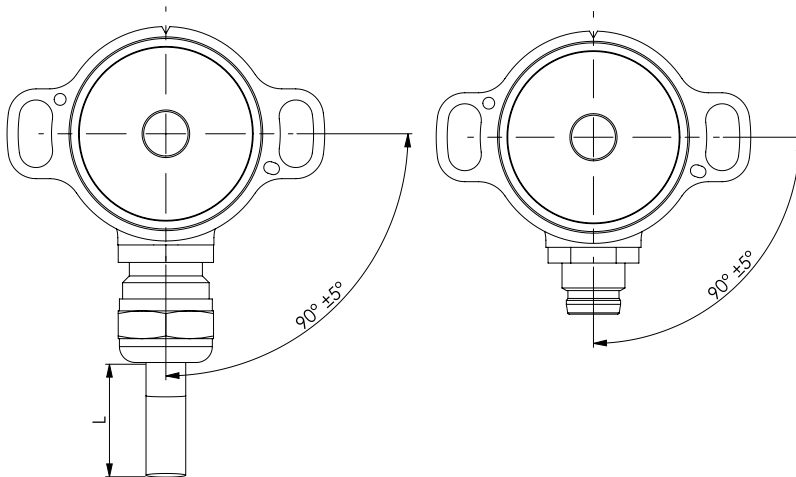

The orientation of the M8 connector pins relative to the encoder housing is not defined and differs from one encoder to the next. When using angled connectors in combination with axial outlet, the orientation of the cable outlet is thus not defined.

If you need a defined orientation of the cable outlet, please choose our housings with radial cable outlet and use straight mating connectors.

**Cable specs for option PG(R) (round control cable)**

Option	Standard cable length L	Number of single strands (depends on electronics)	Cable sheath Ø or width	Single strands cross section	Allowed tolerance (L)	Minimum bending radius
PG PGR	Standard 1000 mm	3		AWG26	-20 mm to +40 mm	10 x D Ø (D = cable sheath diameter Ø)
		6				
		8				
		10		AWG28		
		12				

Cables delivered with cable shield

(\*) Tolerances according IPC Association

**Cable length tolerances – custom lengths**

Length L	Tolerance
≤ 0.3 m	+25 mm / -20 mm
> 0.3 m - 1.5 m	+40 mm / -20 mm
> 1.5 m - 3 m	+100 mm / -40 mm
> 3 m - 7.5 m	+150 mm / -60 mm

Wire harness length measured from sensor face including connector. Minimum cable length: 0.08 m (for round cable). Please contact us for lengths > 3 m regarding handling and packaging.

Mechanical and Environmental data	
Mechanical angle of rotation 1.)	Endless
Lifetime 2.)	Mechanically unlimited
Max. operational speed (with shaft sealing)	<p>The maximum actuation speed is not limited mechanically. The maximum permissible actuation speed [rev./min] is calculated in relation to the resolution. For absolute encoders:</p> <div style="border: 1px solid black; padding: 5px; width: fit-content; margin: 10px auto;"> <math display="block">rev./min. (@max. resolution) = \frac{1}{2^{Resolution\ in\ Bit} * Update\ rate\ in\ s} * 60s</math> </div> <p>For incremental encoders:</p> <div style="border: 1px solid black; padding: 5px; width: fit-content; margin: 10px auto;"> <math display="block">Max. rev./min. = \frac{Limit\ Frequency\ \frac{1}{s} * 60s}{Number\ of\ Pulses}</math> </div>
Operating temperature range	Option M8 (connector) <ul style="list-style-type: none"> <li>▪ -30 to +80°C</li> </ul> Option PG (cable gland incl. cable) <ul style="list-style-type: none"> <li>▪ -30 to +85°C cable fixed</li> <li>▪ -10 to +85°C cable in movement</li> </ul>
Storage temperature range	-30 to +105°C
Protection grade (IEC 60529) front side	IP67
Protection grade (IEC 60529) rear side	Option PG: IP68 (cable ends excluded) Option M8: IP67 (when mated with IP67 type M8 cable)
Vibration (DIN EN 60068-2-64:2008 + A1: 2019)	±1.5 mm / 30 g / 10 to 2000 Hz / 16 frequency cycles (3x4 h)
Shock (DIN EN 60068-2-27)	400 m/s <sup>2</sup> / 6 ms / half sine (100±5) shocks
Housing diameter	Ø 25 mm
Housing depth	In dependency to the electrical connection position: <ul style="list-style-type: none"> <li>▪ axial 28.25 mm (variant with M8 connector)</li> <li>▪ radial 19.35 mm (variant with M8 connector)</li> </ul>
Shaft diameter	No limitation (customer side)
Masse (zirka)	HTx25K with connector M8(R), 19 g HTx25K with cable gland and 1 m signal cable PG(R), 48 g

1.) According IEC 60393

2.) Determined by climatic conditions according to IEC 68-1, para. 5.3.1 without load collectives

Immunity / Electrostatic Discharge / REACH / RoHS	
EN 61000-4-3 RF sine wave	Class A
EN 61000-4-6 Conducted sine wave	Class A
EN 61000-4-8 Power frequency magnetic fields	Class A
EN 61000-4-2 ESD	Class B
REACH Regulation (EC) 1907/2006 including the SVHC list	
RoHS Directive 2011/65/EU	

**Mechanical and environmental data, miscellaneous**

Sensor mounting	<p>Standard mounting is done by using M4 screws. A rotation of +/- 7.5° is possible to find the zero point in the application when installing the magnet.</p> <p>Alternatively, it is possible to align the rotary encoder exactly to the magnet using cylindrical pins (1.5 mm) in the application (a rotation is then not possible, however).</p> <p>There are two variants/two drilling patterns to choose from:</p> <ul style="list-style-type: none"> <li>▪ Variant S (standard): Cylindrical pins are installed by the customer in the application and the rotary encoder is attached and fixed using M4 screws</li> <li>▪ Variant P: Cylindrical pins are pre-installed on the rotary encoder. The drillings for the pins must be implemented on the mounting position in the application. This variant is suitable, for example, for mounting on thin sheet metal.</li> </ul>
Mounting hardware included	<p>none</p> <p>(Note: With hole pattern P, the cylinder pins are already fixed on the rotary encoder)</p>
Fastening torque per screw for fastening of the rotary encoder	<p>≤ 1.4 Nm (M4 screws, thread tensile strength class 5.6)</p> <p>For screw securing, the use of a medium-strength thread securing adhesive is recommended</p>
Material shaft	Stainless steel
Material housing	Aluminium
Material cable gland (PG)	Stainless steel
Material connector M8	CuZn nickel-plated

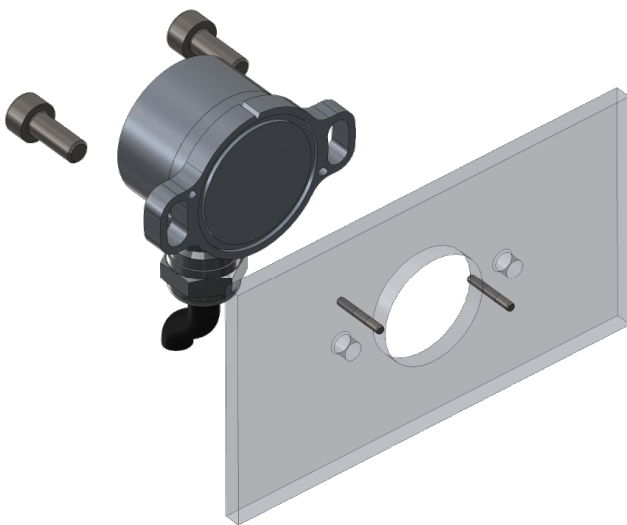

**Mounting example of the variant for drilling pattern S**  
 Mount using 2 M4 screws, optional exact alignment using 2 cylindrical pins h8 1.5 (e.g. ISO 2338 B)  
 (screws and pins not included)

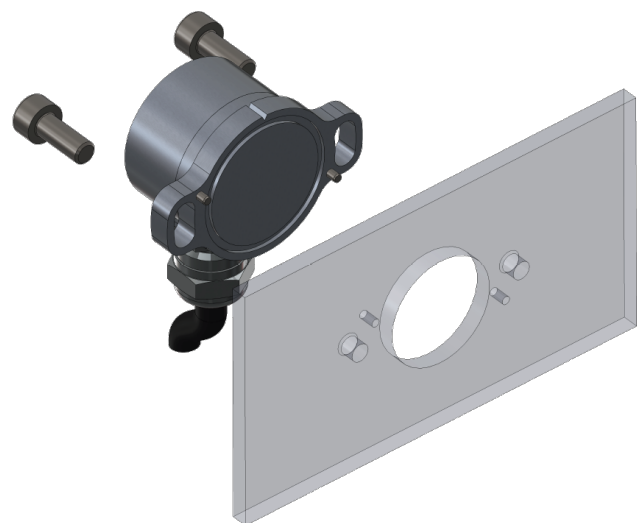

**Mounting example of the variant for drilling pattern P:**  
 Mount using 2 M4 screws, exact alignment is ensured using cylindrical pins h8 1.5 pre-assembled at encoder  
 (screws not included)

**Definition of the zero position**

**Output at the zero point:**

- HTA25K (analogue outputs): Output signal 0% full scale (F. S.)
- HTP25K (PWM output): duty cycle 10% (10% duty cycle)
- HTS25K (serial output): Output signal 0% full scale (F. S.)
- HTI25K (incremental output): The index signal is output (Z)

The position of the zero position cannot be mechanically defined due to the rotationally symmetrical magnet.  
The sense of rotation is defined when looking at the flat front of the rotary encoder:

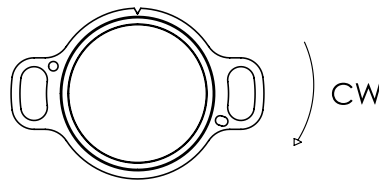

**Signal definition for custom rotation angles**

Custom angles <360°

When programming the electrical angle of rotation of <360°, the remaining non-effective range of rotation is divided equally into high and low.

