

Data Sheet for Angle Sensors

Optical incremental Kit Encoder

Series OPTS



Illustration shows version for shaft diameters up to 10 mm

- Optical resolution until 10.000 pulses per revolution
- 15.6 mm housing depth
- Applicable for shaft diameters 2...25 mm
- 2 channels + index
- Supply voltage 5 VDC
- Output TTL
- Temperature range -25°..100° C

High resolution kit encoder, quick and safe to install in the application using special installation tools. A round hole in the rear cover is available for long shafts.

Electrical Data

Output signal	5 V - A, B, Z-Index (option A, B)
Number of pulses	1000..10000 pulses per rev. (other resolutions on request)
Output voltage high	≥ 2 V @ IOH = -5 mA max. (3.5 V typ. @ no load)
Output voltage low	≤ 0.5 V @ IOL = 5 mA max. (0.25 V typ. @ no load)
Limit frequency	300 kHz
Supply voltage	5 VDC ±10 %
Power consumption (no load)	≤ 85 mA (typ. 72 mA)
Output capacity	min. -5 mA / max. 5 mA
Output electronics	TTL
Switch-on delay	50 ns (rise time) / 50 ns (fall time)

Mechanical and Environmental Data, Miscellaneous

Mechanical angle of rotation /stroke 1.)	360° without stop
Max. allowed operational speed	Formula for calculation:
For ≥ 4000 and ≤ 5000 pulses per rev.	max. rpm. = (21.6 x 10E6) / pulses per rev.
For > 5000 pulses per rev.	max. rpm = (43.2 x 10E6) / pulses per rev.
Max. acceleration	250000 rad/sec ²

Data Sheet for Angle Sensors

Optical incremental Kit Encoder

Series OPTS

Mechanical and Environmental Data, Miscellaneous

Operating temperature range	-25 °C up to +100 °C
Storage temperature range	-40 °C up to +100 °C
Vibration (IEC 68-2-6, Test Fc)	20 g / 5 until 2000 Hz / sine waveform
Housing diameter / length	61.21 mm x 55.98 mm
Housing depth	15.62 mm
Shaft diameter	2..25 mm
Shaft type	Hub for solid shafts
Permissible axial play	±0.25 mm
Permissible eccentricity + radial play	0.10 mm
Minimum shaft length incl. axial play	11.3 mm
Maximum shaft length incl. axial play	13.3 mm (closed back cover) >13.3mm (with circular hole in back cover)
Max. radial load	< 1 N
Connection type	Contact pins for soldering pitch 2.54 or compatible to Molex Plug (connection without possibility for interlocking)
Connection position	Radial
Sensor mounting	With 2 or 3 screws (not included in delivery)
Mass	app. 36 g
Fastening parts included in delivery	Mounting tools consisting of a centering tool and a spacer tool 1 x per delivery 2 x 4-40 1/2" fillister head screws for mounting the optical module 2 x 4-40 5/8" flat head screws for mounting the housing cover
Material housing	Plastic
Material disc	Mylar
Immunity ESD, human body model (MIL-STD-883, Method 3015.8)	± 4 kV

1.) According IEC 60393

2.) Determined by climatic conditions according to IEC 68-1, para. 5.3.1 without load collectives

Data Sheet for Angle Sensors

Optical incremental Kit Encoder

Series OPTS

Order Code

Description	Selection: standard=black/bold , possible <i>options=grey/italic</i>					
Series:	OPTS					
Shaft diameter						
<i>Option 2 mm</i>		2				
<i>Option 3 mm</i>		3				
<i>Option 3.175 mm</i>		3,175				
Standard: 4 mm		4				
<i>Option 5 mm</i>		5				
Standard: 6 mm		6				
<i>Option 6.35 mm (1/4")</i>		6,35				
<i>Option 8 mm</i>		8				
<i>Option 10 mm</i>		10				
<i>Option 12 mm</i>		12				
<i>Option 14 mm</i>		14				
<i>Option 20 mm</i>		20				
<i>Option 25 mm</i>		25				
Resolution in pulses per revolution:						
<i>Option 1000 ppr.</i>			1000			
<i>Option 2048 ppr.</i>			2048			
Standard: 4000 ppr.			4000			
<i>Option 4096 ppr.</i>			4096			
<i>Option 5000 ppr.</i>			5000			
Standard: 7200 ppr.			7200			
<i>Option 8000 ppr.</i>			8000			
<i>Option 8192 ppr.</i>			8192			
<i>Option 10000 ppr.</i>			10000			
Supply voltage:						
Standard: 5 V				5		
Output signal:						
Standard: A+B+Z					BZ	
<i>Option: A+B (For > 2048 ppr. only option BZ available)</i>					B	
Output electronics:						
Standard: TTL						TTL
Back cover:						
Standard: Closed (without hole in back cover)						A
<i>Option with circular hole in back cover for longer shafts</i>						B

Order example OPTS

Requirement:

Shaft diameter 6 mm, resolution 4000 pulses per revolution, supply voltage 5 V, 2 channels A+B+Z, output electronics TTL, back cover without circular hole for longer shafts

Example for order code: OPTS 6 4000 5 BZ A

For higher quantities or on-going demand, additional options are available as described below

- Special connector and cable design

Data Sheet for Angle Sensors



Optical incremental Kit Encoder

Series OPTS

Drawing

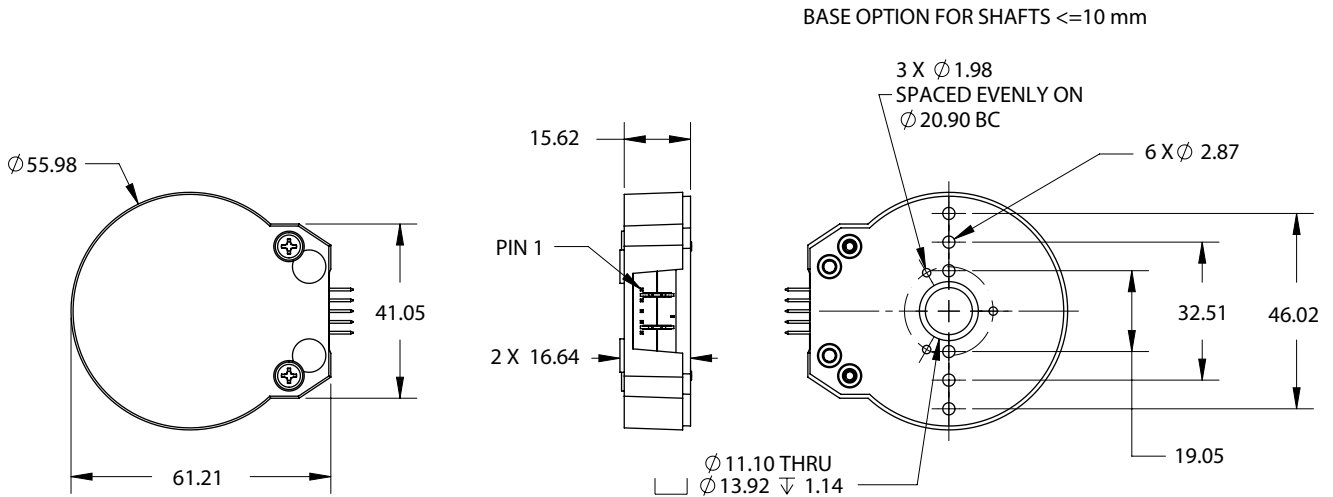

BASE OPTION FOR SHAFTS > 10 MM

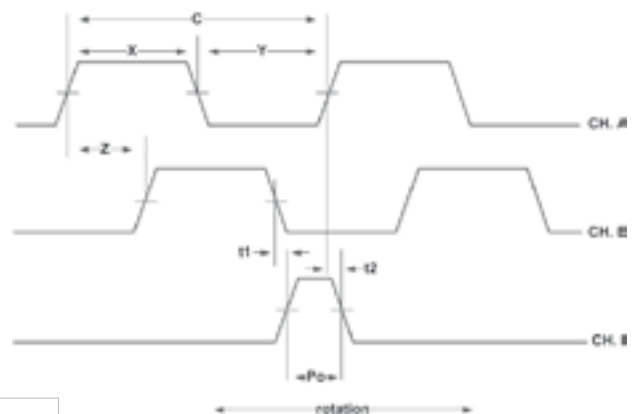
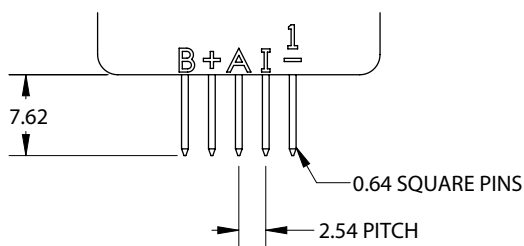
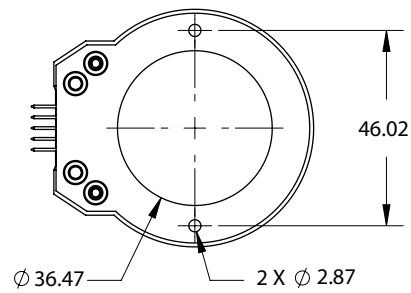

Connection diagram

PIN 1	GND
PIN 2	Index (Z)
PIN 3	Channel A
PIN 4	+5 VDC
PIN 5	Channel B

Dimensions in mm

Recommendation for mating connector:

Standard, contact pins (TTL output):
MOLEX: KK 254 crimp housing, 5 circuits, series 2695
KK254 crimp terminals series 2759

Assembly instruction for shaft diameters < 10 mm

During transport, storage, installation and operation, ESD guidelines must be observed. Avoid touching the disc in the area of the increments.

Step 1:

Place encoder base onto mounting surface. Slip centering tool over the shaft and into the center hole of the base. While holding pressure on the centering tool, tighten mounting screws. Remove centering tool.

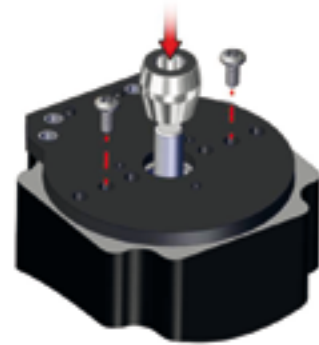

Step 2:

Place spacer tool around shaft. Slip hubdisk assembly onto shaft with codewheel disk towards top until it bottoms out against spacer tool.

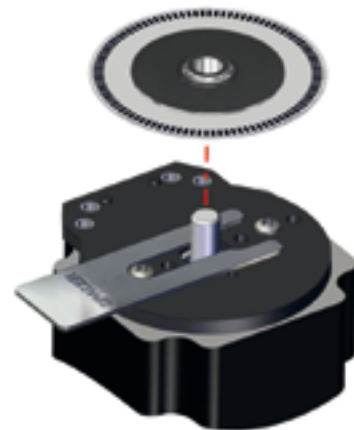

Hub Set Screw:
max. 0,3 Nm torque

Step 3:

Tighten set screw with provided hex wrench while pressing down on hub. Remove spacer tool.

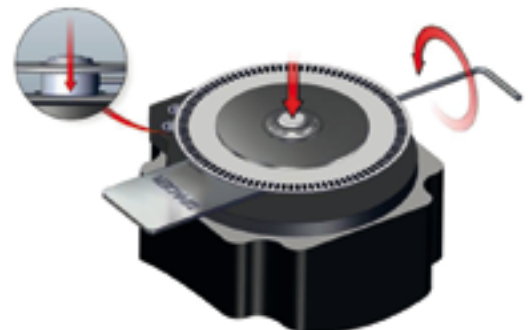

Step 4:

Orient module with connector pins toward the top. Gently slide module onto base. Fit module onto the two alignment pins on base and secure with two 4-40 x 1/2" pan head screws (supplied).

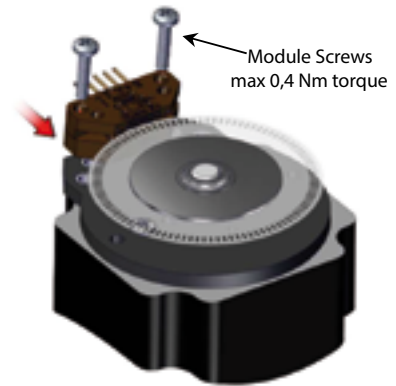

Step 5:

Place cover over assembly and secure with two 4-40 x 5/8" flat head screws (supplied).

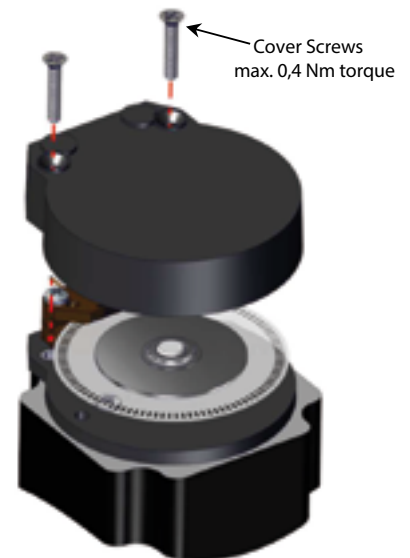

Assembly instruction for shaft diameters ≥ 10 mm

During transport, storage, installation and operation, ESD guidelines must be observed. Avoid touching the disc in the area of the increments.

Step 1:

Place encoder base onto mounting surface. Slip centering tool over the shaft and into the center hole of the base. While holding pressure on the centering tool, tighten mounting screws. Remove centering tool.

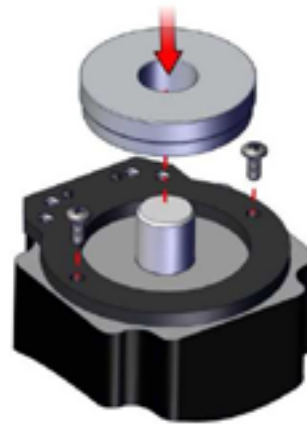

Step 2:

Push the spacer tool onto the bottom section of the hubdisk assembly. Slip hubdisk assembly onto shaft and slide down until spacer tool bottoms out against encoder base.

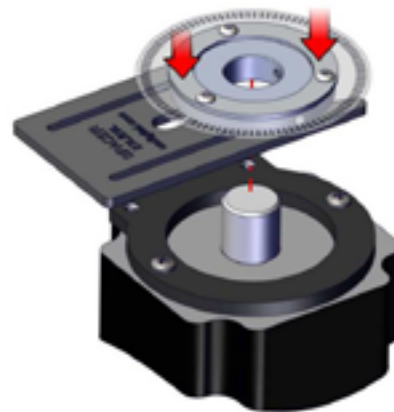

Step 3:

Tighten set screw with provided hex wrench while pressing down on hub. Remove spacer tool.

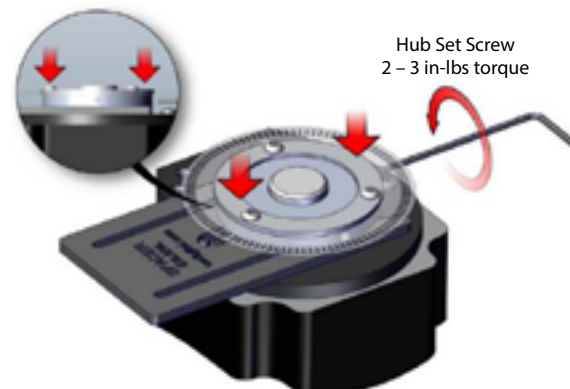

Step 4:

Slip optical module into position until the two alignment pins slip into holes of module (thick side of module towards bottom). Secure with two 4-40 x 1/2" screws (supplied).

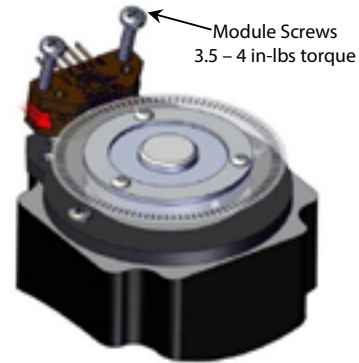

Step 5:

Place cover over assembly and secure with two 4-40 5/8" flat head screws (supplied).

