

Data Sheet for sensor accessories

Encoder to counter interface chip

Series ICS



The LS7083/4N allows incremental shaft encoders to drive standard up/down counters. Connect the encoder quadrature outputs to the A and B inputs. The LS7083N outputs can connect directly to the up and down clock inputs of counters such as 74193 or 40193. The next generation Encoder to Counter Interface chips are now available and recommended for new applications (DIP package, LS7183N / LS7184N, or SOIC package, LS7183N-S / LS7184N-S).

- x1 or x4 resolution multiplication
- TTL and CMOS compatible
- Low current (micro-amps)
- 8-pin DIP package
- No external clocks required
- Drive standard Up/Down counters
- Monolithic CMOS



The LS7166 is a CMOS, 24-bit counter that can be programmed to operate in several different modes. The operating mode is set up by writing control words into internal control registers. There are three 6-bit and one 2-bit control registers for setting up the functional circuit characteristics. In addition to the control registers, there is a 5-bit output status register that indicates the current counter status. The IC communicates with external circuits through an 8-bit three state I/O bus. Control and data words are written into the LS7166 through the bus. In addition to the I/O bus, there are a number of discrete inputs and outputs to facilitate instantaneous hardware-based control functions and instantaneous status indication.

- Programmable count modes
- DC to 25MHz count frequency
- 8-Bit I/O Bus for P communication and control
- 24-Bit comparator for pre-set count comparison Readable status register
- Input/Output TTL and CMOS compatible
- 3V to 5.5V operation
- 20-pin DIP

Order Code

Description

Selection: standard=black/bold, possible options=grey/cursive

Series:

SCHALTKREIS TYP

Type:

LS7083N-S

LS7083N

LS7084N

LS7166

Optional LS7084N-S

LS7083-SOIC

LS7083-DIP

LS7084-DIP

LS7166-DIP

LS7084-SOIC

Order example series ICS:

Requirement:

LS7083N-S

Example for order code:

SCHALTKREIS TYP LS7083-SOIC

LS7083N LS7084N

QUADRATURE CLOCK CONVERTER

June 2015

FEATURES:

- x1 and x4 mode selection
- Up to 16MHz output clock frequency
- Programmable output clock pulse width
- On-chip filtering of inputs for optical or magnetic encoder applications.
- TTL and CMOS compatible I/Os
- +3V to +12V operation ($V_{DD} - V_{SS}$)
- **LS7083N, LS7084N** (DIP);
- **LS7083NS, LS7084NS** (SOIC) - See Figure 1

Applications:

- Interface incremental encoders to Up / Down Counters (See Figure 6A and Figure 6B)
- Interface rotary encoders to Digital Potentiometers (See Figure 7)

DESCRIPTION:

The **LS7083N** and **LS7084N** are CMOS quadrature clock converters. Quadrature clocks derived from optical or magnetic encoders, when applied to the A and B inputs of the **LS7083N** or **LS7084N**, are converted to strings of Up Clocks and Down Clocks (**LS7083N**) or to a Clock and an Up/Down direction control (**LS7084N**). These outputs can be interfaced directly with standard Up/Down counters for direction and position sensing of the encoder.

INPUT/OUTPUT DESCRIPTION:

RBIAS (Pin 1)

Input for external component connection. A resistor connected between this input and V_{SS} adjusts the output clock pulse width (Tow). For proper operation, the output clock pulse width must be less than or equal to the A, B pulse separation ($TOW \leq T_{PS}$).

V_{DD} (Pin 2)

Supply Voltage positive terminal.

V_{SS} (Pin 3)

Supply Voltage negative terminal.

A (Pin 4)

Quadrature Clock Input A. This input has a filter circuit to validate input logic level and eliminate encoder dither.

B (Pin 5)

Quadrature Clock Input B. This input has a filter circuit identical to input A.

Mode (Pin 6)

Mode is a 3-state input to select resolutions x1, x2 or x4. The selected resolution multiplies the input quadrature clock rate by 1, 2 and 4, respectively, in producing the outputs \overline{UPCK} / \overline{DNCK} and CLK (see Figure 2).

The Mode input logic levels selects resolutions as follows:

Logic 0 = x1 Float = x2 Logic 1 = x4

PIN ASSIGNMENT - TOP VIEW

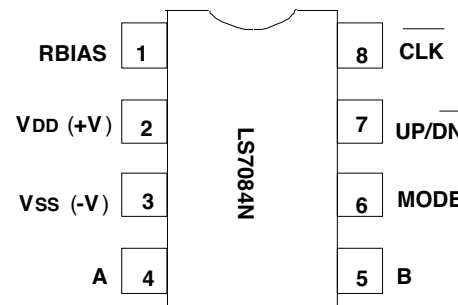
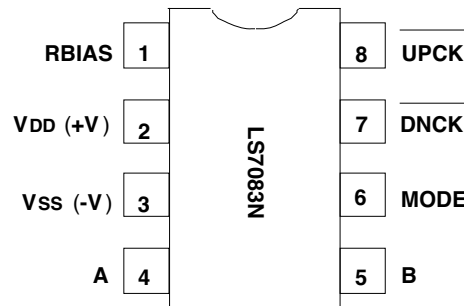

FIGURE 1

LS7083N - \overline{DNCK} (Pin 7)

In **LS7083N**, this is the DOWN Clock Output. This output consists of low-going pulses generated when A input lags the B input.

LS7084N - $\overline{UP/DN}$ (Pin 7)

In **LS7084N**, this is the count direction indication output. When A input leads the B input, the $\overline{UP/DN}$ output goes high indicating that the count direction is UP. When A input lags the B input, $\overline{UP/DN}$ output goes low, indicating that the count direction is DOWN.

LS7083N - \overline{UPCK} (Pin 8)

In **LS7083N**, this is the UP Clock output. This output consists of low-going pulses generated when A input leads the B input.

LS7084N - CLK (Pin 8)

In **LS7084N**, this is the combined UP Clock and DOWN Clock output. The count direction at any instant is indicated by the $\overline{UP/DN}$ output (Pin 7).

NOTE: For the **LS7084N**, the timing of \overline{CLK} and $\overline{UP/DN}$ requires that the counter interfacing with **LS7084N** counts on the rising edge of the CLK pulses.

ABSOLUTE MAXIMUM RATINGS:

PARAMETER	SYMBOL	VALUE	UNITS
DC Supply Voltage	$V_{DD} - V_{SS}$	16	V
Voltage at any input	V_{IN}	$V_{SS}-0.3$ to $V_{DD}+0.3$	V
Operating temperature	T_A	-20 to +85	°C
Storage temperature	T_{STG}	-55 to 150	°C

DC ELECTRICAL CHARACTERISTICS: (Unless otherwise specified $V_{DD} = 3V$ to $12V$ and $T_A = -20^\circ C$ to $+85^\circ C$)

PARAMETER	SYMBOL	MIN	TYP	MAX	UNITS	CONDITION
Supply Voltage	V_{DD}	3	-	12	V	-
Supply Current	I_{DD}	-	1.5	1.65	mA	$V_{DD} = 12V$, all input frequencies=0 Hz and $R_{BIAS} = 2M\Omega$

MODE INPUT:

Logic 0	V_{ml}	-	-	0.5	V	-
Logic 1	V_{mh}	$V_{DD} - 0.5$	-	-	V	-
Logic Float	V_{mf}	$(V_{DD}/2) - 0.5$	$V_{DD}/2$	$(V_{DD}/2) + 0.5$	V	-
Logic 0 Input Current	I_{ml}	-	2.2	4.2	μA	$V_{DD} = 3V$
	I_{ml}	-	3.5	6.9	μA	$V_{DD} = 5V$
	I_{ml}	-	8.3	16.2	μA	$V_{DD} = 12V$
Logic 1 Input Current	I_{mh}	-	-2	-9.8	μA	$V_{DD} = 3V$
	I_{mh}	-	-3.4	-6.6	μA	$V_{DD} = 5V$
	I_{mh}	-	-8.2	-16	μA	$V_{DD} = 12V$

A,B INPUTS:

Logic 0	V_{ABl}	-	-	$0.25V_{DD}$	V	-
Logic 1	V_{ABh}	$0.7V_{DD}$	-	-	V	-
Input Current	I_{ABlk}	-	0	10	nA	-

RBIAS INPUT:

External Resistor	R_B	2K	-	10M	Ω	-
-------------------	-------	----	---	-----	----------	---

ALL OUTPUTS:

Sink Current	I_{ol}	-	-3.2	-	mA	
	I_{ol}	-	-4.8	-	mA	
	I_{ol}	-	-7.2	-	mA	
Source Current	I_{oh}	-	1.7	-	mA	
	I_{oh}	-	2.2	-	mA	
	I_{oh}	-	3.1	-	mA	

TRANSIENT CHARACTERISTICS ($T_A = -20^\circ C$ to $+85^\circ C$)

PARAMETER	SYMBOL	MIN	TYP	MAX	UNITS	CONDITION
Output Clock Pulse Width	T_{OW}	540			ns	$V_{DD} = 3V$
	T_{OW}	180			ns	$V_{DD} = 5V$
	T_{OW}	60			ns	$V_{DD} = 12V$
A,B INPUTS: Validation Delay	T_{VD}	-	450	-		$V_{DD} = 3V$
	T_{VD}	-	200	-		$V_{DD} = 5V$
	T_{VD}	-	90	-		$V_{DD} = 12V$
Phase Delay	T_{PS}	$T_{VD}+T_{OW}$		∞	s	-
Pulse Width	T_{PW}	$2T_{PS}$	-	∞	s	-
Frequency	$f_{A,B}$	-		$1/(2T_{PW})$	Hz	-
Input to output Delay	T_{DS}	-	490	565	ns	$V_{DD} = 3V$
	T_{DS}	-	220	345	ns	$V_{DD} = 5V$
	T_{DS}	-	125	135	ns	$V_{DD} = 12V$

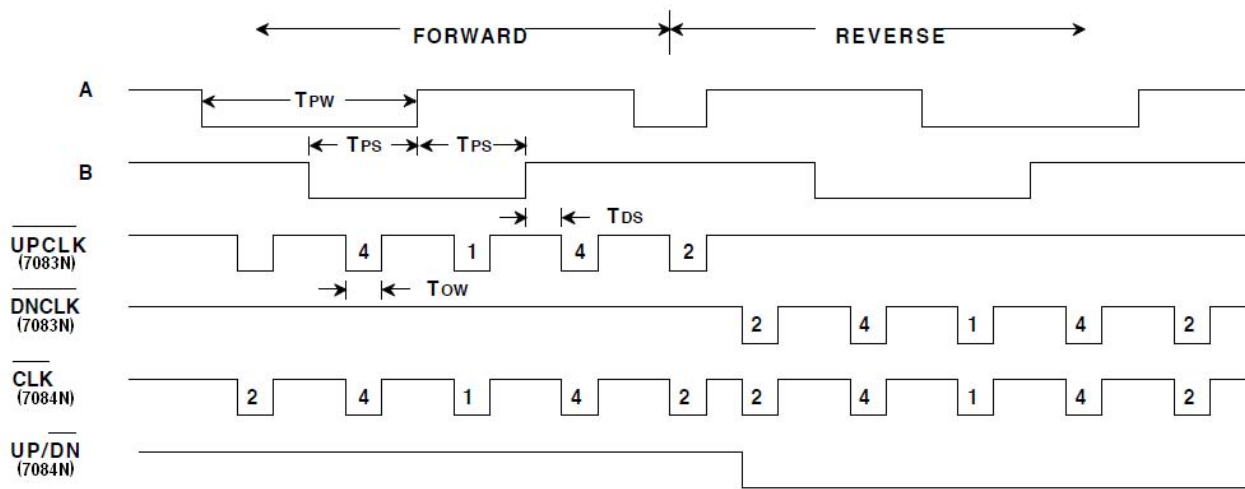

NOTE: Output clocks labeled 1, 2 and 4 have the following interpretations.

- 1: Generated in x1, x2 and x4 modes
- 2: Generated in x2 and x4 modes only
- 4: Generated in x4 mode only

FIGURE 2. LS7083N / LS7084N INPUT / OUTPUT TIMING

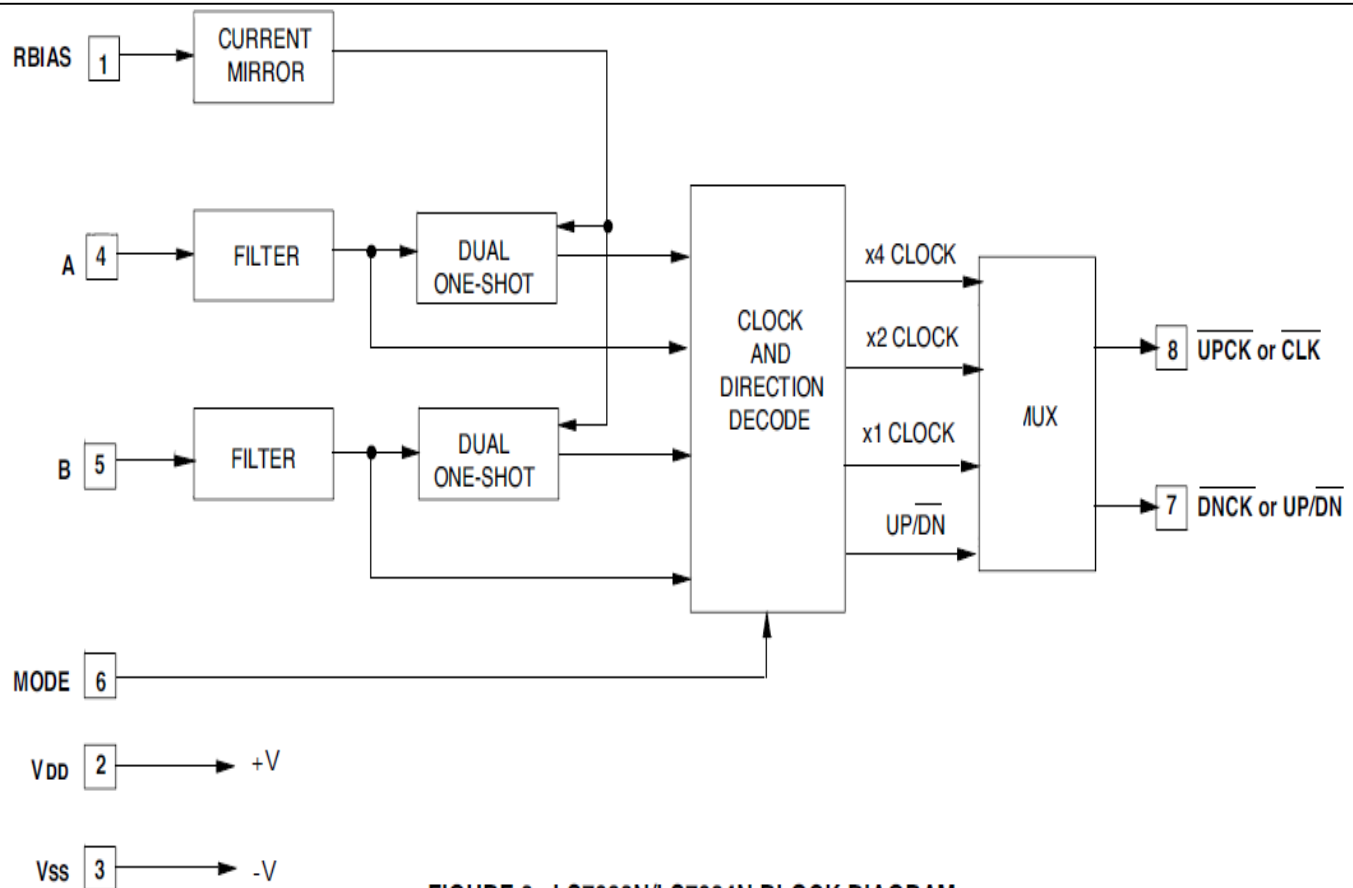

FIGURE 3. LS7083N/LS7084N BLOCK DIAGRAM

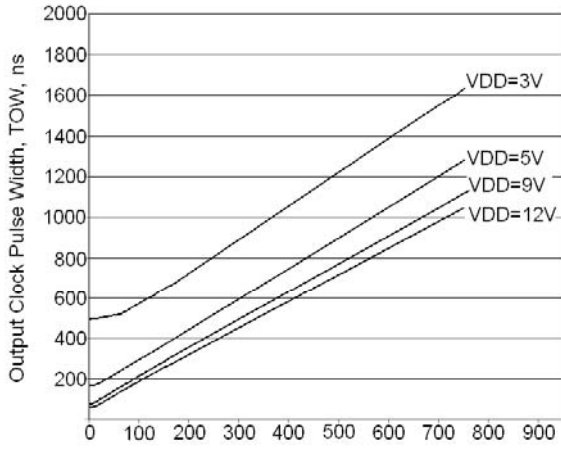

Figure 4. T_{OW} vs. R_{BIAS} (R in KΩ)

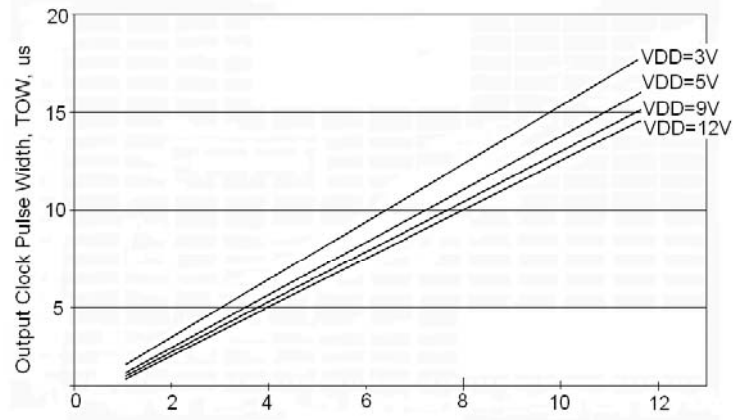

Figure 5. T_{OW} vs. R_{BIAS} (R in MΩ)

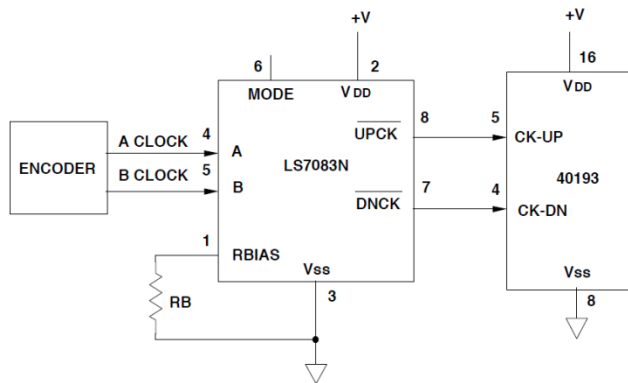

Figure 6A. Typical application for 7083N in x4 mode

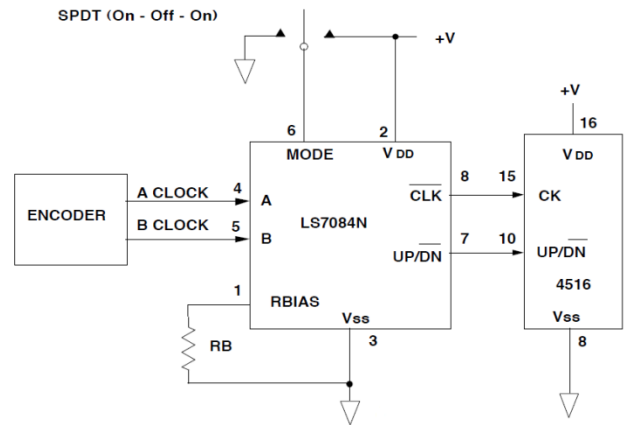

Figure 6B. Typical application for LS7084N in x2 mode

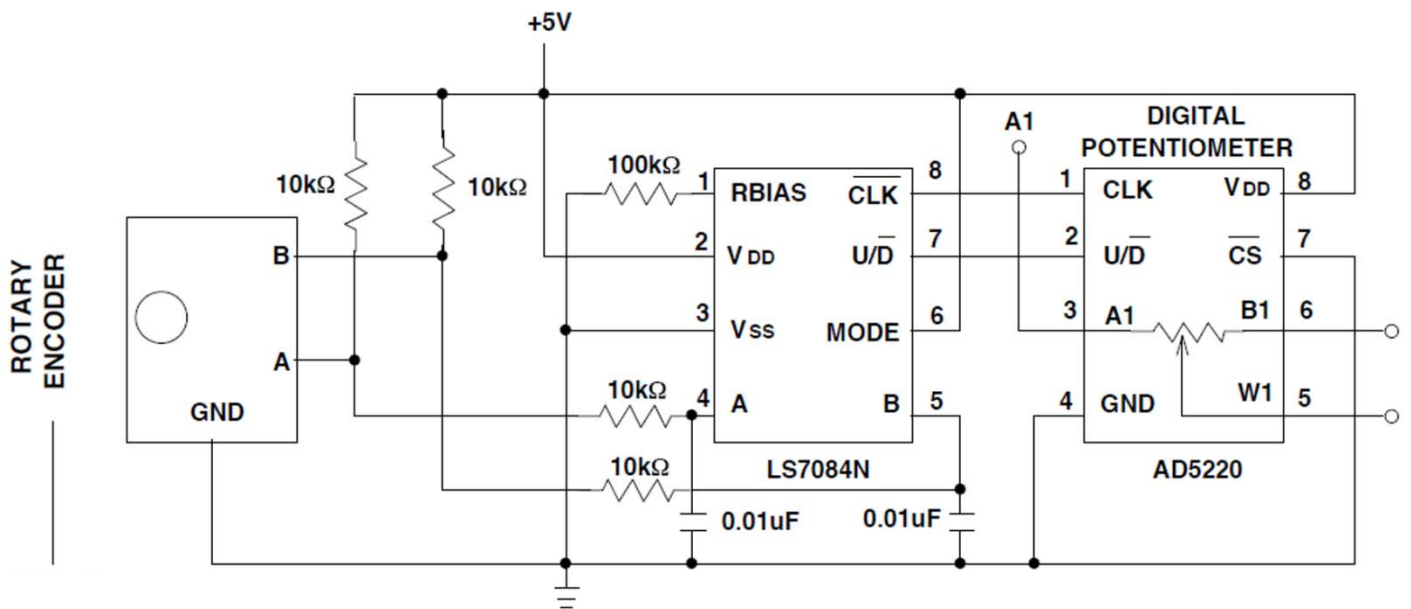

Figure 7. Rotary encoder control of digital potentiometer

LS7166

24-BIT QUADRATURE COUNTER

October 2017

FEATURES:

- Programmable modes are: Up/Down, Binary, BCD, 24 Hour Clock, Divide-by-N, x1 or x2 or x4 Quadrature and Single-Cycle.
- DC to 25MHz Count Frequency.
- 8-Bit I/O Bus for uP Communication and Control.
- 24-Bit comparator for pre-set count comparison.
- Readable status register.
- Input/Output TTL and CMOS compatible.
- 3V to 5.5V operation ($V_{DD} - V_{SS}$).
- LS7166 (DIP); LS7166-S (SOIC); LS7166-TS (24-Pin TSSOP) - **See Figure 1** -

GENERAL DESCRIPTION:

The LS7166 is a CMOS, 24-bit counter that can be programmed to operate in several different modes. The operating mode is set up by writing control words into internal control registers (see Figure 8). There are three 6-bit and one 2-bit control registers for setting up the circuit functional characteristics. In addition to the control registers, there is a 5-bit output status register (OSR) that indicates the current counter status. The IC communicates with external circuits through an 8-bit three state I/O bus. Control and data words are written into the LS7166 through the bus. In addition to the I/O bus, there are a number of discrete inputs and outputs to facilitate instantaneous hardware based control functions and instantaneous status indication.

REGISTER DESCRIPTION:

Internal hardware registers are accessible through the I/O bus (D0 - D7) for READ or WRITE when $\overline{CS} = 0$. The C/D input selects between the control registers (C/D = 1) and the data registers (C/D = 0) during a READ or WRITE operation. (See Table 1)

PIN ASSIGNMENTS - Top View

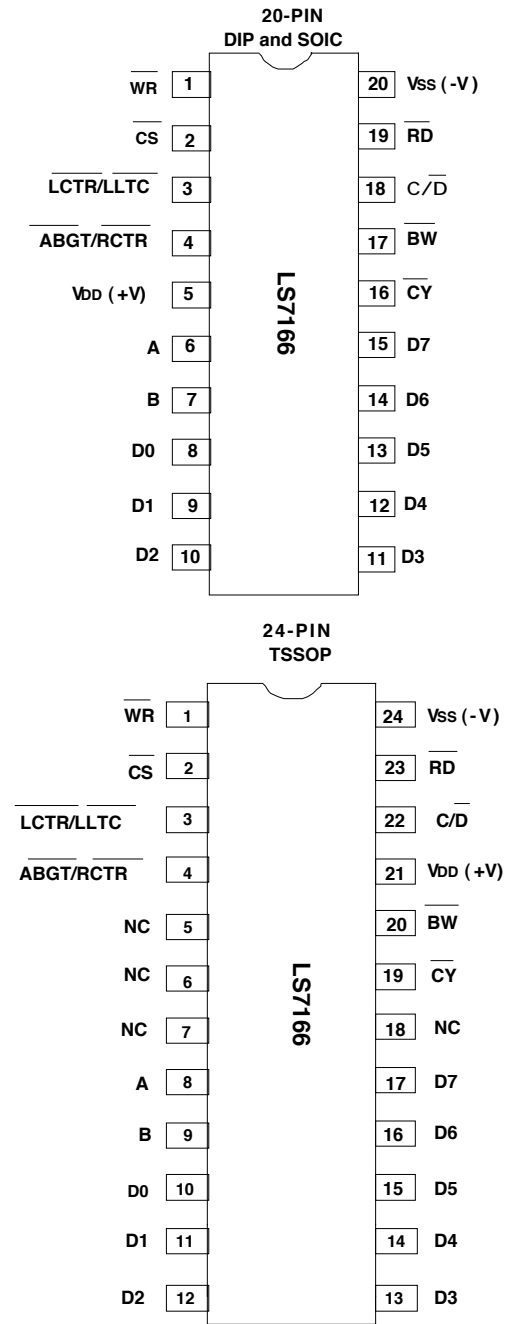
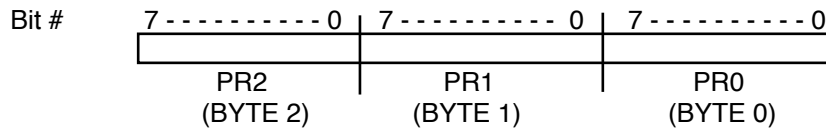

FIGURE 1

PR (Preset register). The PR is the input port for the CNTR. The CNTR is loaded with a 24 bit data via the PR. The data is first written into the PR in 3 WRITE cycle sequence of Byte 0 (PR0), Byte 1 (PR1) and Byte 2 (PR2). The address pointer for PR0/PR1/PR2 is automatically incremented with each write cycle.
 Accessed by: WRITE when $C/\overline{D} = 0$, $\overline{CS} = 0$.



Standard Sequence for Loading PR and Reading CNTR:

- 1 → MCR ; Reset PR address pointer
- WRITE PR ; Load Byte 0 and into PR0 increment address
- WRITE PR ; Load Byte 1 and into PR1 increment address
- WRITE PR ; Load Byte 2 and into PR3 increment address
- 8 → MCR ; Transfer PR to CNTR

MCR (Master Control Register). Performs register reset and load operations. Writing a "non-zero" word to MCR does not require a follow-up write of an "all-zero" word to terminate a designated operation.
 Accessed by: WRITE when $C/\overline{D} = 1$, $\overline{CS} = 0$.

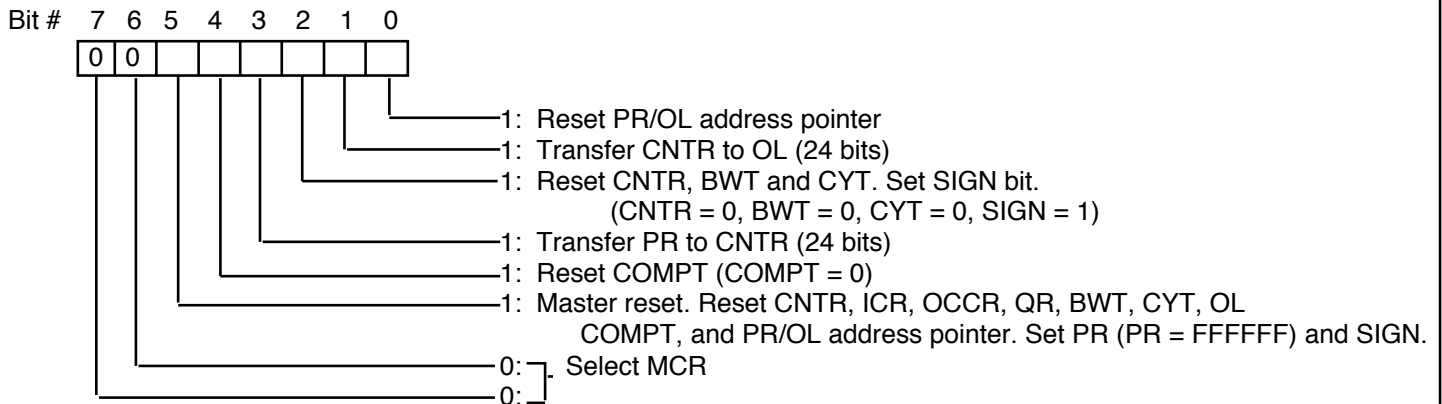

NOTE: Control functions may be combined.

ICR (Input Control Register). Initializes counter input operating modes.
 Accessed by: WRITE when $C/\overline{D} = 1$, $\overline{CS} = 0$.

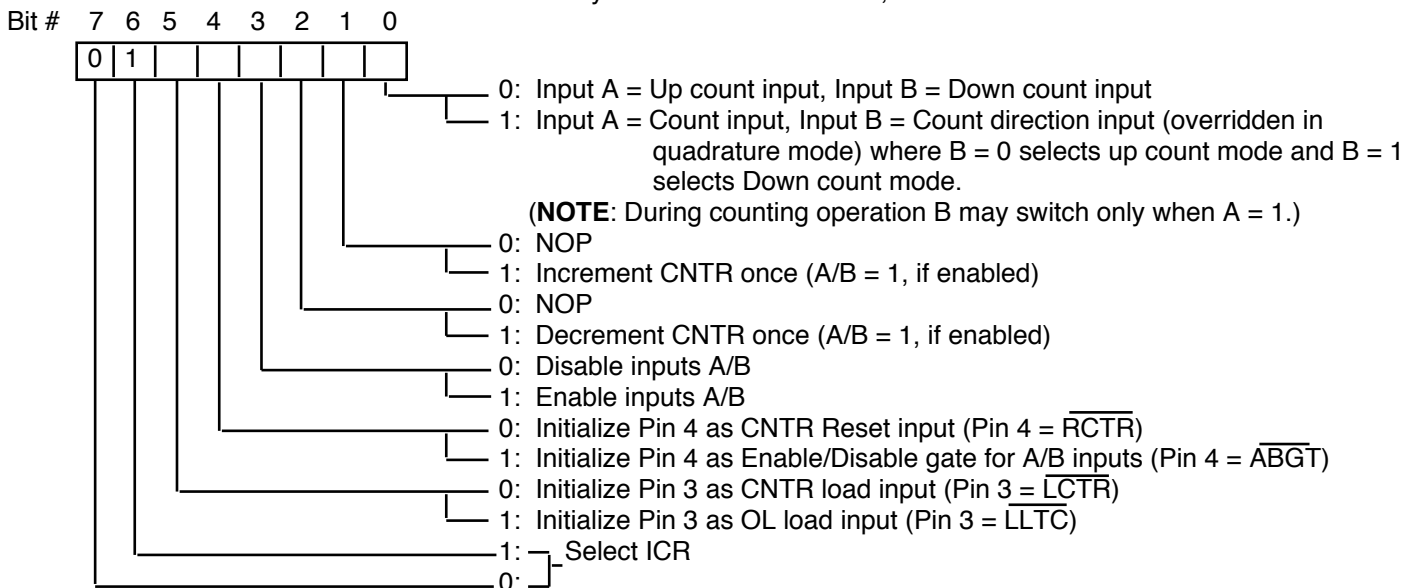

NOTE: Control functions may be combined.

TABLE 1 - Register Addressing Modes

D7	D6	C/D	R \bar{D}	$\bar{W}R$	$\bar{C}S$	COMMENT
X	X	X	X	X	1	Disable Chip for READ/WRITE
0	0	1	1	$\bar{1}$	0	Write to Master Control Register (MCR)
0	1	1	1	$\bar{1}$	0	Write to input control register (ICR)
1	0	1	1	$\bar{1}$	0	Write to output/counter control register (OCCR)
1	1	1	1	$\bar{1}$	0	Write to quadrature register (QR)
X	X	0	1	$\bar{1}$	0	Write to preset register (PR) and increment register address counter.
X	X	0	$\bar{1}$	1	0	Read output latch (OL) and increment register address counter
X	X	1	$\bar{1}$	1	0	Read output status register (OSR).

X = Don't Care

OSR (Output Status Register). Indicates CNTR status: Accessed by: READ when $C/\bar{D} = 1, \bar{C}S = 0$.

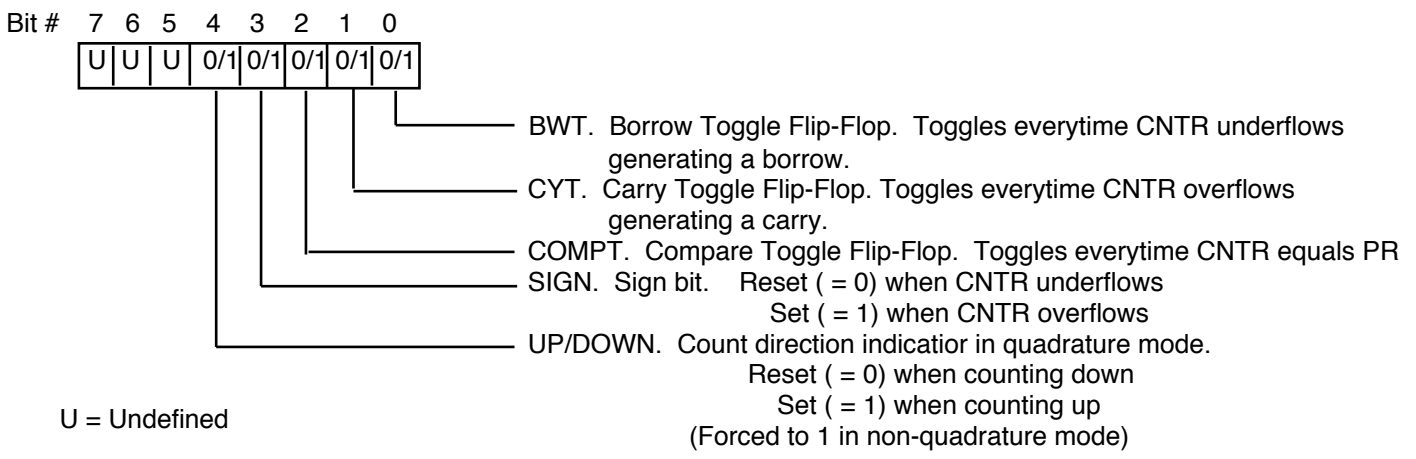

OL(Output latch). The OL is the output port for the CNTR. The 24 bit CNTR Value at any instant can be accessed by performing a CNTR to OL transfer and then reading the OL in 3 READ cycle sequence of Byte 0 (OL0), Byte 1 (OL1) and Byte 2 (OL2). The address pointer for OL0/OL1/OL2 is automatically incremented with each READ cycle. Accessed by: READ when $C/\bar{D} = 0, \bar{C}S = 0$.

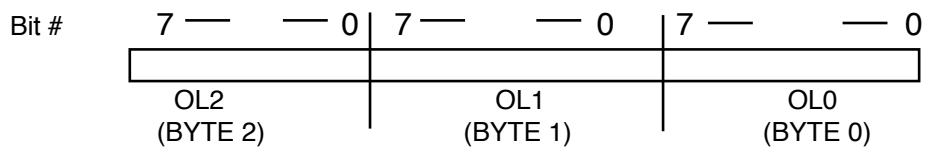

- Standard Sequence for Loading and Reading OL:
- 3 → MCR ; Reset OL address pointer and Transfer CNTR to OL
 - READ OL ; Read Byte 0 and increment address
 - READ OL ; Read Byte 1 and increment address
 - READ OL ; Read Byte 2 and increment address

OCCR (Output Control Register) Initializes CNTR and output operating modes.
 Accessed by : WRITE when $C/\overline{D} = 1$, $\overline{CS} = 0$.

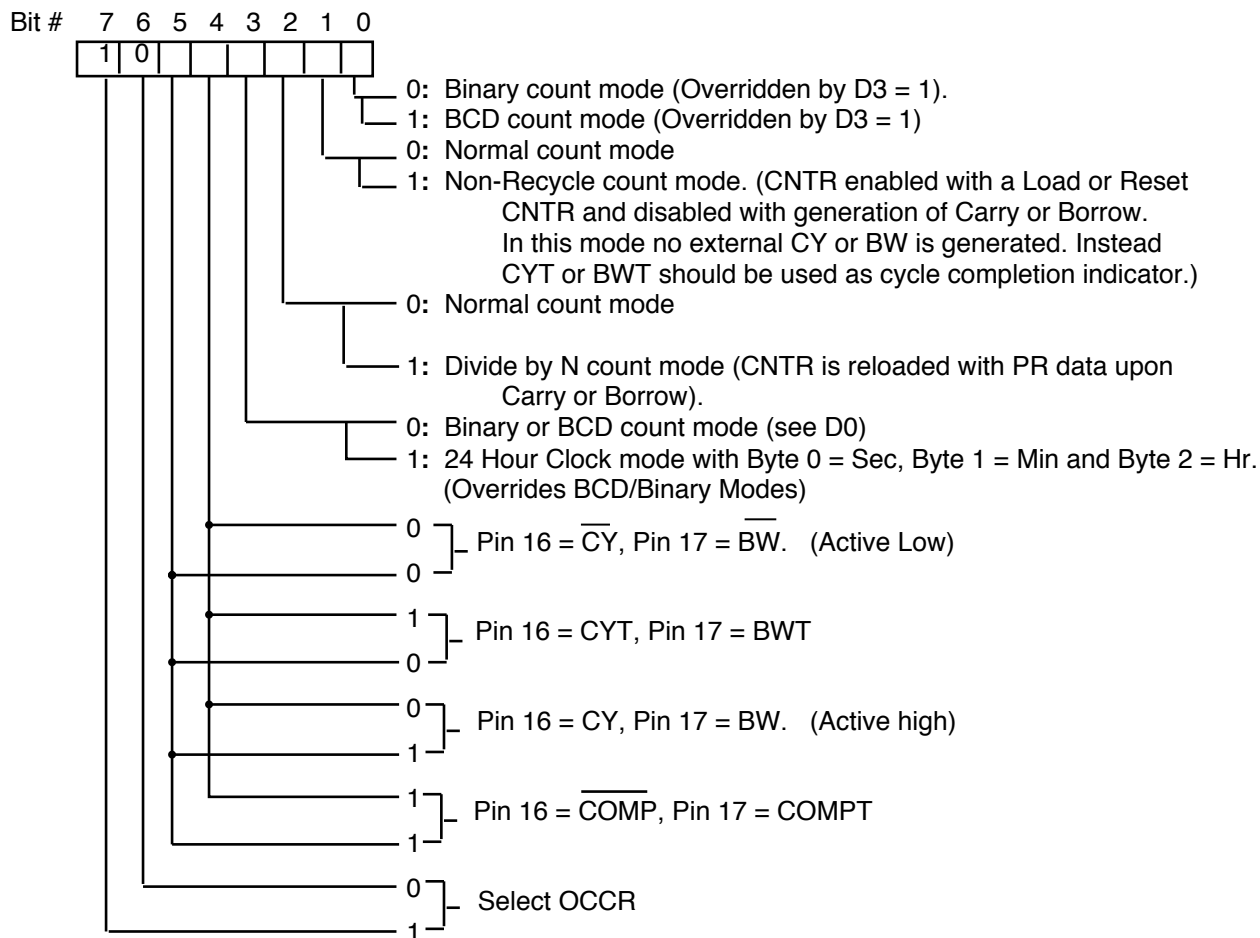

QR (Quadrature Register). Selects quadrature count mode (See Fig. 7)
 Accessed by: WRITE when $C/\overline{D} = 1$, $\overline{CS} = 0$.

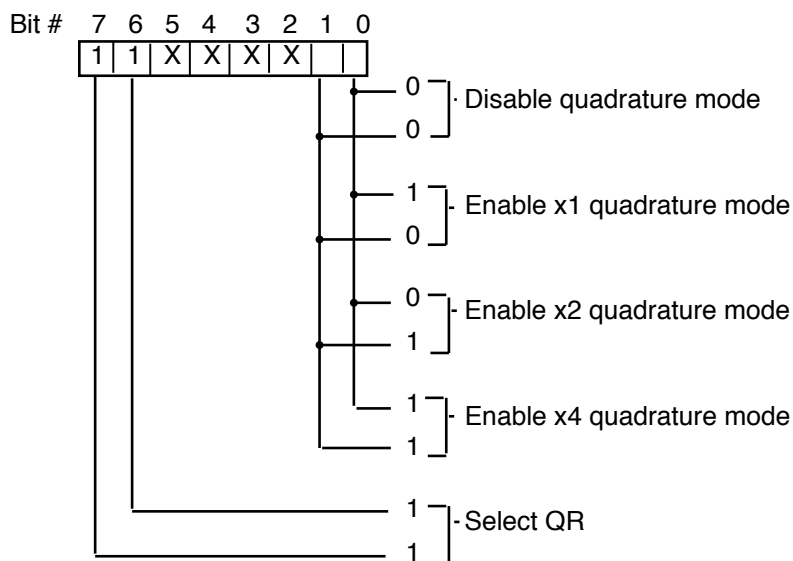

X = Don't Care

I/O DESCRIPTION:**(See REGISTER DESCRIPTION for I/O Prgramming.)**

Data-Bus (D0 - D7) (Pin 8 - Pin 15). The 8-line data bus is a three-state I/O bus for interfacing with the system bus.

\overline{CS} (Chip Select Input) (Pin 2). A logical "0" at this input enables the chip for Read and Write.

\overline{RD} (Read Input) (Pin 19). A logical "0" at this input enables the OSR and the OL to be read on the data bus.

\overline{WR} (Write Input) (Pin 1). A logical "0" at this input enables the data bus to be written into the control and data registers.

C/\overline{D} (Control/Data Input) (Pin 18). A logical "1" at this input enables a control word to be written into one of the four control registers or the OSR to be read on the I/O bus. A logical "0" enables a data word to be written into the PR, or the OL to be read on the I/O bus.

A (Pin 6). Input A is a programmable count input capable of functioning in three different modes, such as up count input, down count input and quadrature input. In non-quadrature mode, the counter advances on the rising edge of Input A

B (Pin 7). Input B is also a programmable count input that can be programmed to function either as down count input, or count direction control gate for input A, or quadrature input. In non-quadrature mode, and when programmed as the Down Count input, the counter advances on the rising edge of Input B. When B is programmed as the count direction control gate, B = 0 enables A as the Up Count input and B = 1 enables A as the Down Count input. When programmed as the direction input, B can switch state only when A is high.

$\overline{ABGT}/\overline{RCTR}$ (Pin 4). This input can be programmed to function as either inputs A and B enable gate or as external counter reset input. A logical "0" is the active level on this input. In non-quadrature mode, if Pin 4 is programmed as A and B enable gate input, it may switch state only when A is high (if A is clock and B is direction) or when both A and B are high (if A and B are clocks). In quadrature mode, if Pin 4 is programmed as A and B enable gate, it may switch state only when either A or B switches.

$\overline{LCTR}/\overline{LLTC}$ (Pin 3) This input can be programmed to function as the external load command input for either the CNTR or the OL. When programmed as counter load input, the counter is loaded with the data contained in the PR. When programmed as the OL load input, the OL is loaded with data contained in the CNTR. A logical "0" is the active level on this input.

\overline{CY} (Pin 16) This output can be programmed to serve as one of the following:

- A. \overline{CY} . Complemented Carry out (active "0").
- B. CY. True Carry out (active "1").
- C. CYT. Carry Toggle flip-flop out.
- D. \overline{COMP} . Comparator out (active "0")

\overline{BW} (Pin 17) This output can be programmed to serve as one of the following:

- A. \overline{BW} . Complemented Borrow out (active "0").
- B. BW. True Borrow out (active "1").
- C. BWT. Borrow Toggle flip-flop out.
- D. COMPT. Comparator Toggle output.

VDD (Pin 5) Supply voltage positive terminal.

VSS (Pin 20) Supply voltage negative terminal.

Absolute Maximum Ratings:

Parameter	Symbol	Values	Unit
Voltage at any input	V _{IN}	V _{SS} - 0.3 to V _{DD} + 0.3	V
Operating Temperature	T _A	-40 to +125	°C
Storage Temperature	T _{STG}	-65 to +150	°C
Supply Voltage	V _{DD} - V _{SS}	+7.0	V

DC Electrical Characteristics. (All voltages referenced to V_{SS}.)

T_A = 0° to 85°C, V_{DD} = 3V to 5.5V, f_c = 0, unless otherwise specified)

Parameter	Symbol	Min. Value	Max. Value	Unit	Remarks
Supply Voltage	V _{DD}	3.0	5.5	V	-
Supply Current	I _{DD}	-	350	μA	Outputs open
Input Low Voltage	V _{IL}	0	0.8	V	-
Input High Voltage	V _{IH}	2.0	V _{DD}	V	-
Output Low Voltage	V _{OL}	-	0.4	V	4mA Sink, V _{DD} = 5V
Output High Voltage	V _{OH}	2.5	-	V	200μA Source, V _{DD} = 5V
Input Current	-	-	15	nA	Leakage Current
Output Source Current	I _{SRC}	200	-	μA	V _{OH} = 2.5V, V _{DD} = 5V
Output Sink Current	I _{SINK}	4	-	mA	V _{OL} = 0.4V, V _{DD} = 5V
Data Bus Off-State Leakage Current	-	-	15	nA	-

TRANSIENT CHARACTERISTICS (See Timing Diagrams in Fig. 2 thru Fig. 7,
VDD = 3V to 5.5V, TA = 0° to 85°C, unless otherwise specified)

Parameter	Symbol	Min.Value	Max.Value	Unit
Clock A/B "Low"	TCL	18	No Limit	ns
Clock A/B "High"	TCH	22	No Limit	ns
Clock A/B Frequency (See NOTE 1)	fc	0	25	MHz
Clock UP/DN Reversal Delay	TUDD	100	-	ns
LCTR Positive edge to the next A/B positive or negative edge delay	TLC	100	-	ns
Clock A/B to CY/BW/COMP "low" propagation delay	TCBL	-	65	ns
Clock A/B to CY/BW/COMP "high" propagation delay	TCBH	-	85	ns
LCTR and LLTC pulse width	TLCW	60	-	ns
Clock A/B to CYT, BWT and COMPT "high" propagation delay	TTFH	-	100	ns
Clock A/B to CYT, BWT and COMPT "low" propagation delay	TTFL	-	100	ns
WR pulse width	TWR	60	-	ns
RD to data out delay (CL=20pF)	TR	-	110	ns
CS, RD Terminate to Data-Bus Tri-State	TRT	-	30	ns
Data-Bus set-up time for WR	TDS	30	-	ns
Data-Bus hold time for WR	TDH	30	-	ns
CS set-up time for RD	TSRS	0	-	ns
CS hold time for RD	TSRH	0	-	ns
Back to Back RD delay	TRR	60	-	ns
RD to WR delay	-	60	-	ns
C/D set-up time for RD	TCRS	0	-	ns
C/D hold time for RD	TCRH	30	-	ns
C/D set-up time for WR	TCWS	30	-	ns
C/D hold time for WR	TCWH	30	-	ns
CS set-up time for WR	TSWS	60	-	ns
CS hold time for WR	TSWH	0	-	ns
Back to Back WR delay	Tww	60	-	ns
WR to RD delay	-	60	-	ns
Quadrature Mode:				
Clock A/B Validation delay (See NOTE 1)	Tcqv	-	160	ns
A and B phase delay	TPH	208	-	ns
Clock A/B frequency	fcQ	-	1.2	MHz
CY, BW, COMP pulse width	TCBW	85	200	ns

NOTE 1: In quadrature mode A/B inputs are filtered and required to be stable for at least Tcqv length to be valid.

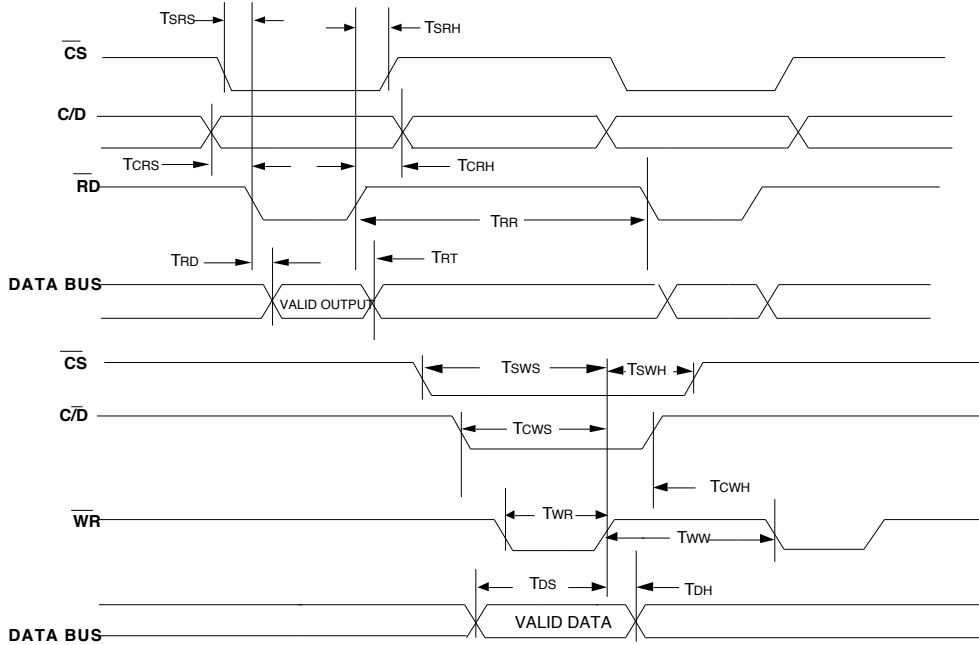
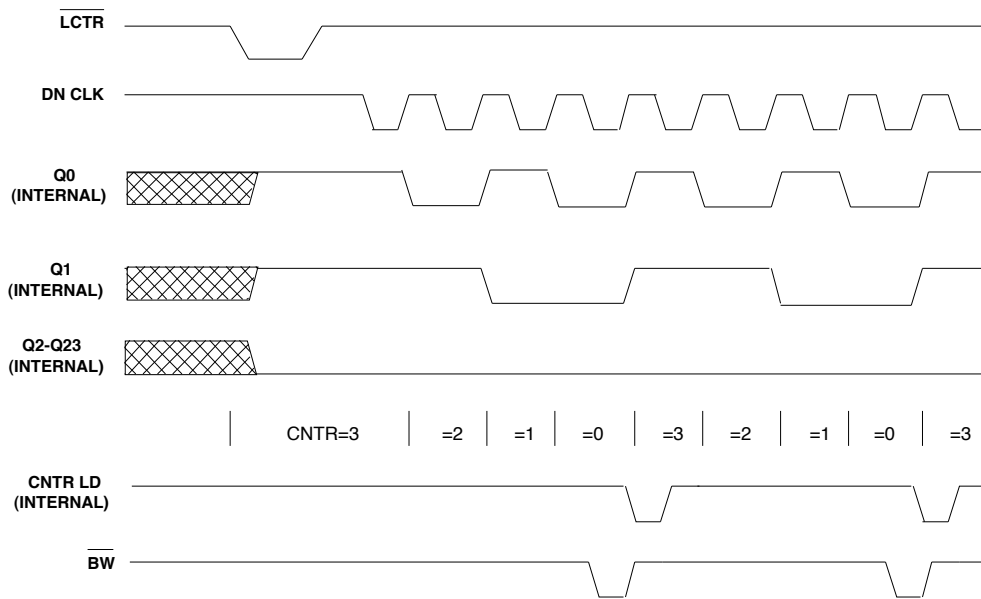

FIGURE 4. READ/WRITE CYCLES



NOTE: EXAMPLE OF DIVIDE BY 4 IN DOWN COUNT MODE

FIGURE 5. DIVIDE BY N MODE

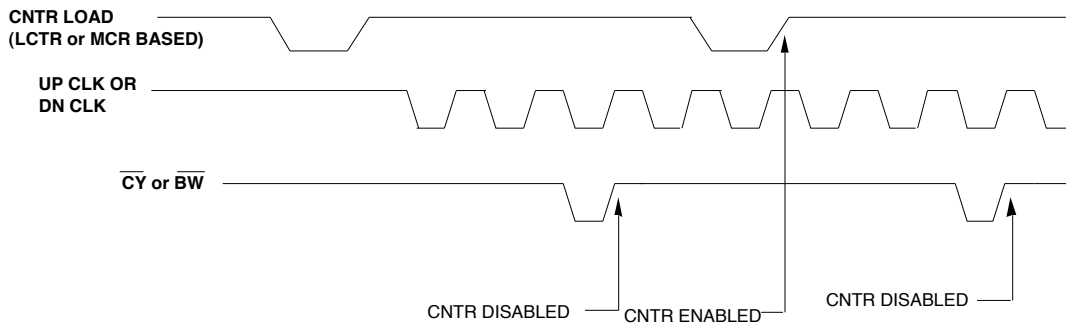

FIGURE 6. CYCLE ONCE MODE

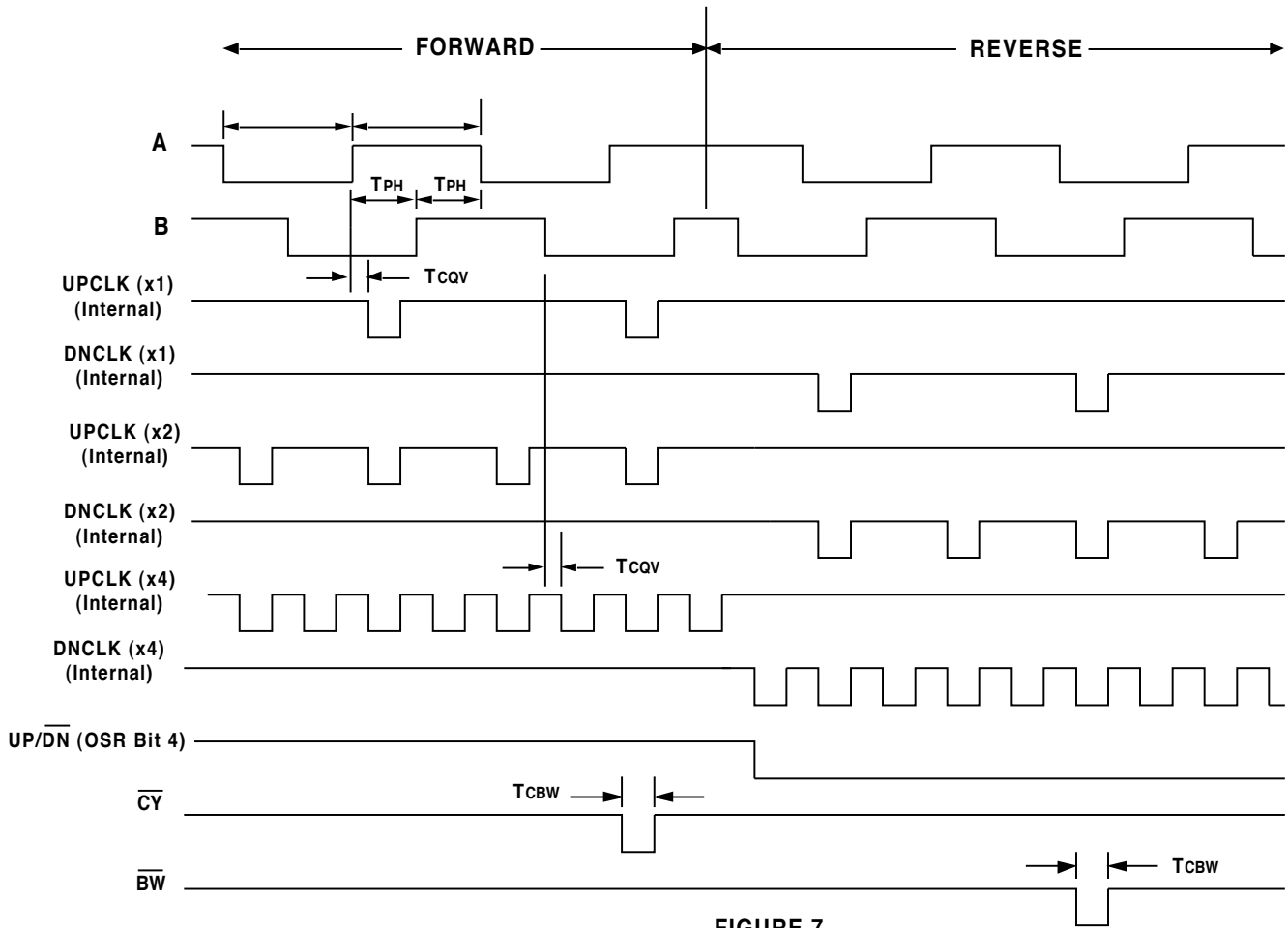

FIGURE 7.
QUADRATURE MODE INTERNAL CLOCKS

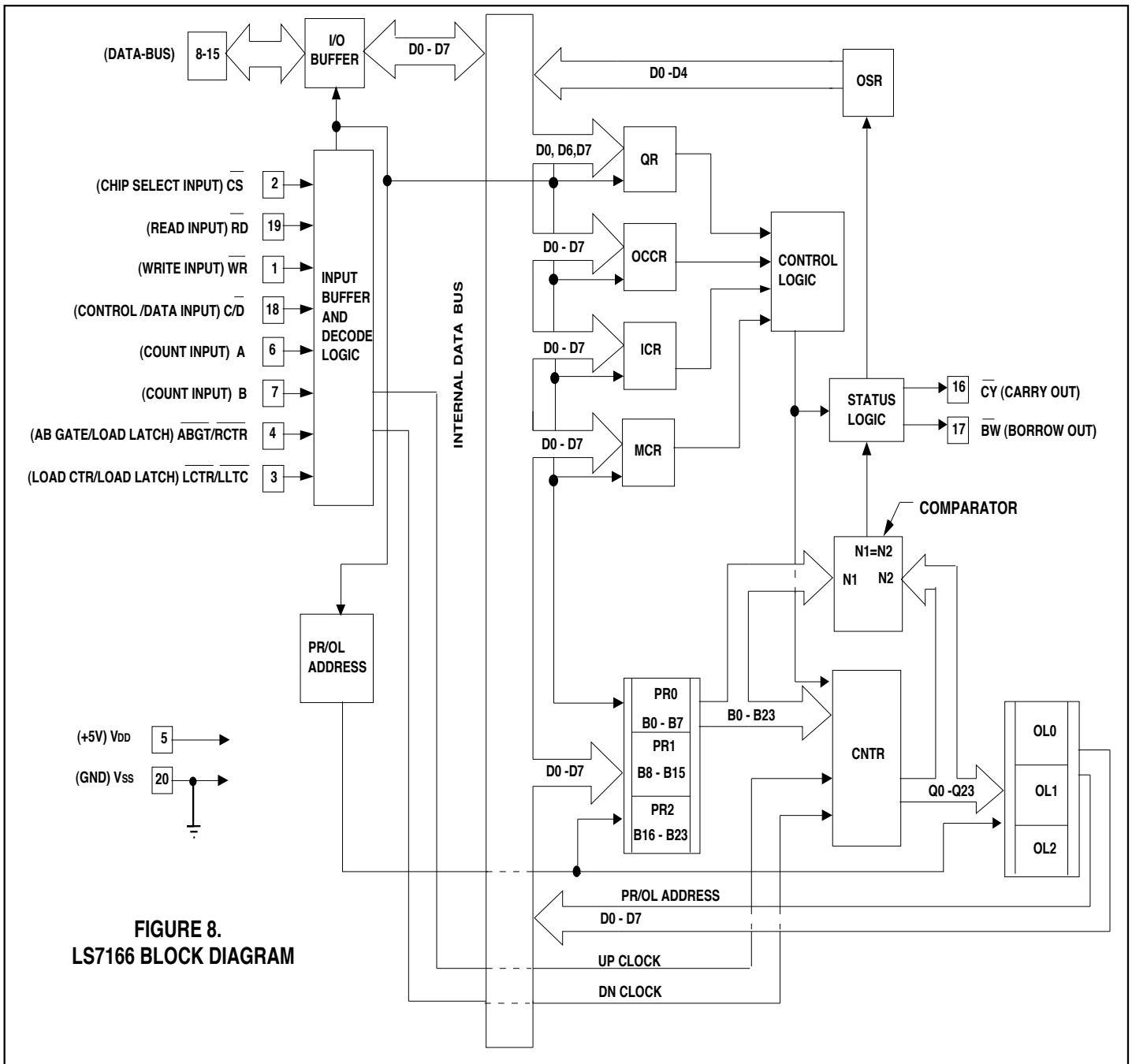
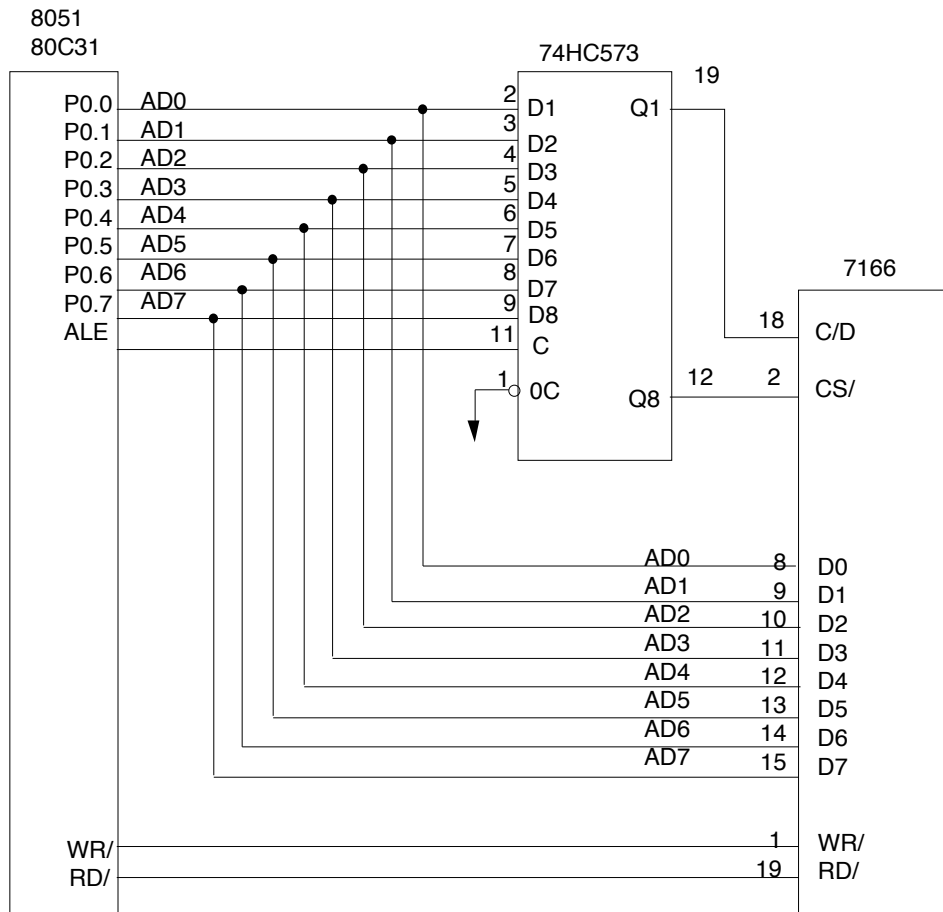

FIGURE 8.
LS7166 BLOCK DIAGRAM

FIGURE 9. 80C31/8051 TO LS7166 INTERFACE IN EXTERNAL ADDRESS MODE



NOTE: Port_0 is open drain output. Add pull-up resistors to all Port_0 i/O lines.

FIGURE 10. 8751 INTERFACE TO LS7166 IN I/O MODE

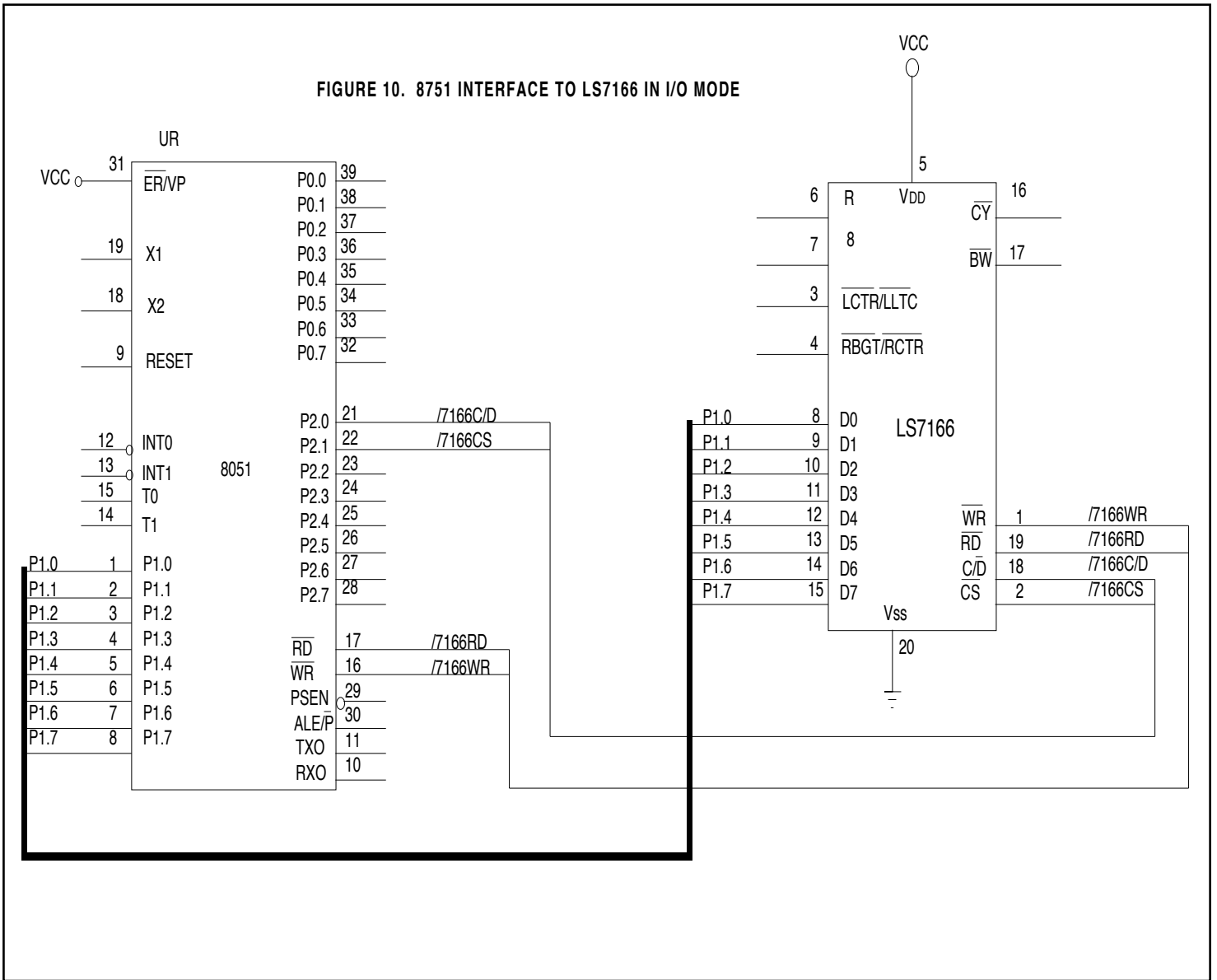

FIGURE 11. LS7166 TO 68HC11 INTERFACE

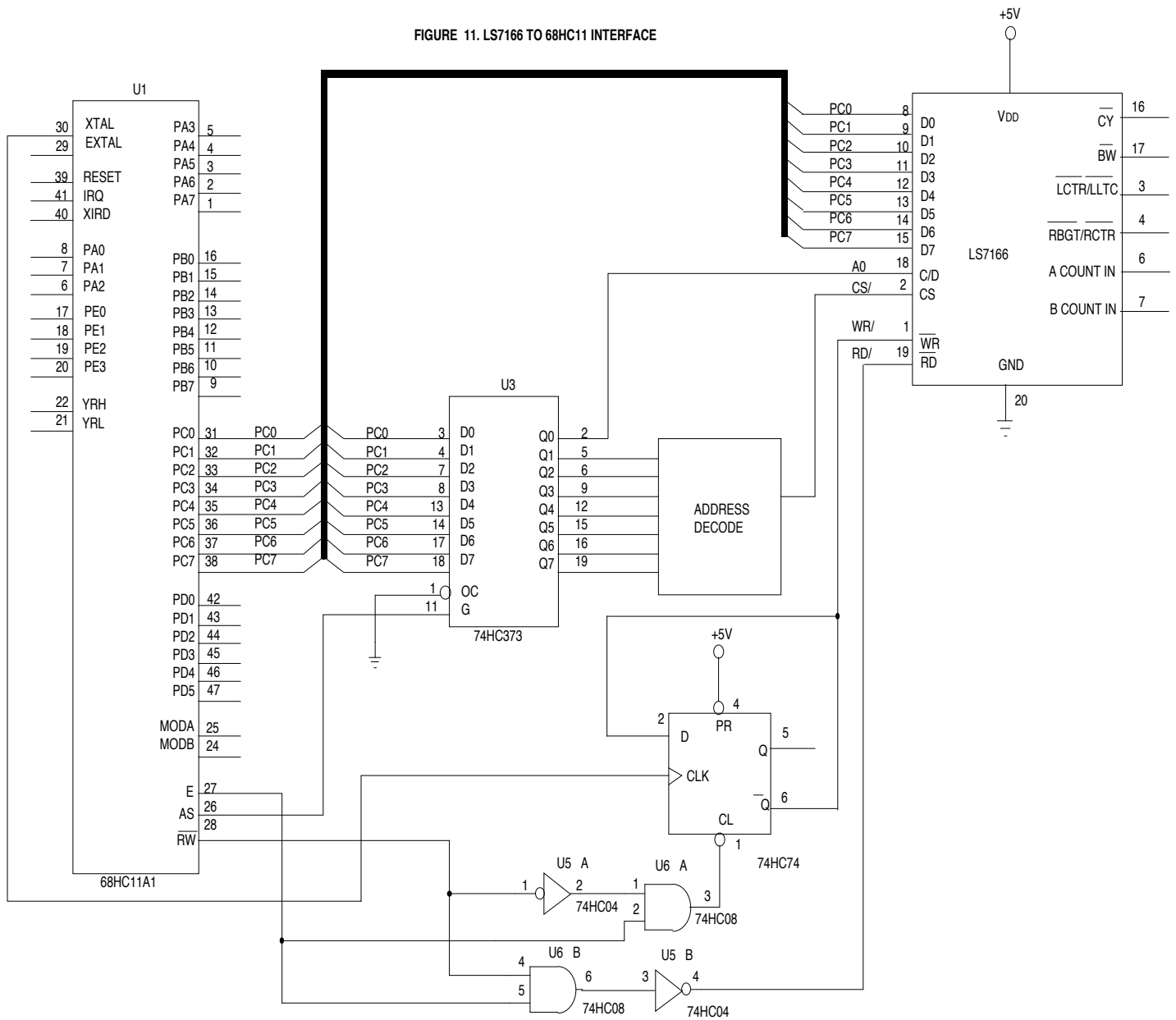

FIGURE 12. LS7166 INTERFACE EXAMPLE

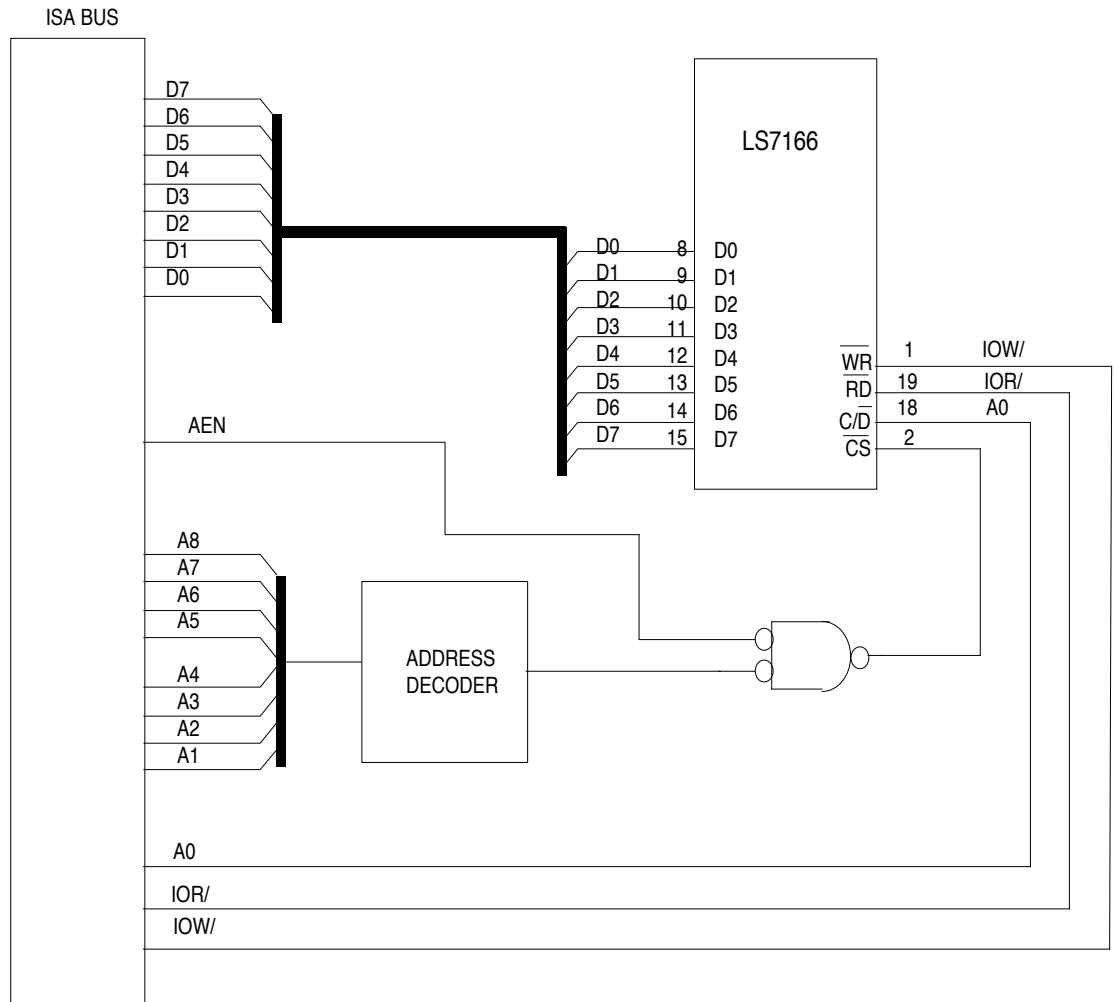
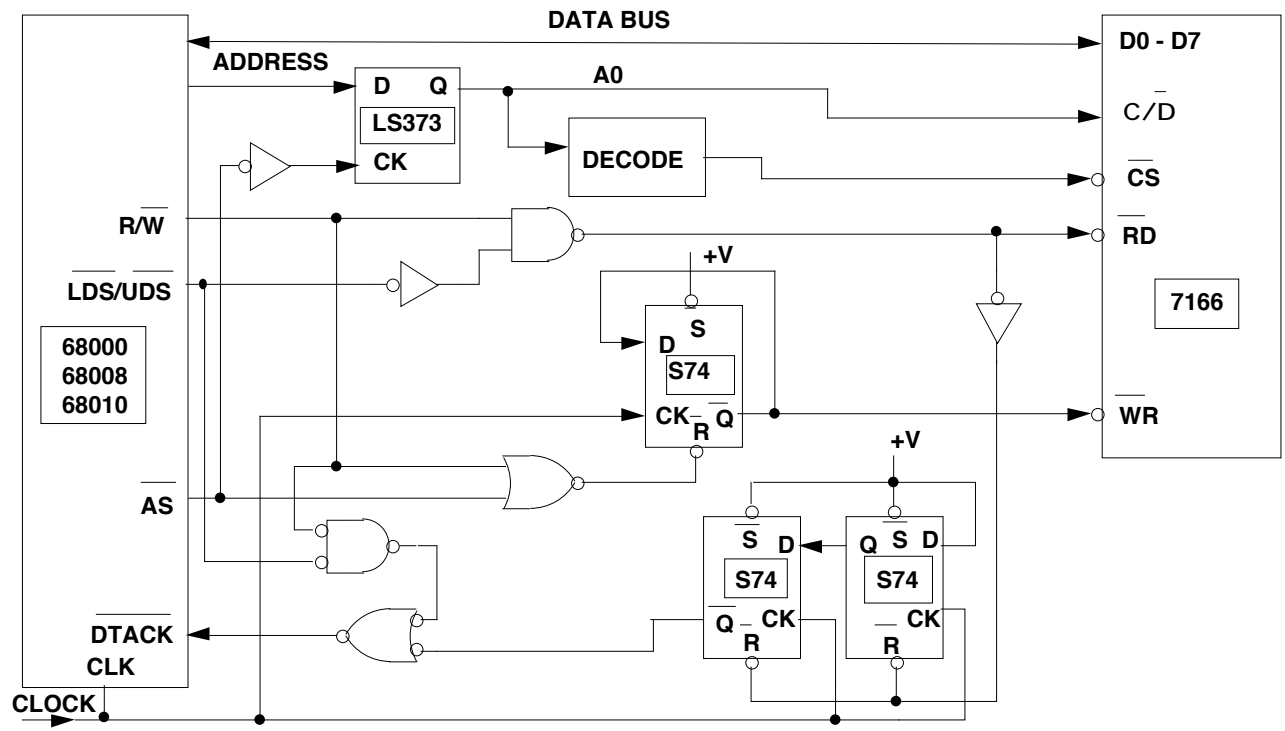

FIGURE 13. 68000 INTERFACE TO LS7166



C Sample Routines for Interfacing with LS7166

```

#include <stdio.h>
#include <stdlib.h>
#include <conio.h>

#define DATAMODE(arg) (arg + 0)
#define CTRLMODE(arg) (arg + 1)

/*****/
/* MCR (Master Control Register) */

/* Select MCR */
#define MCR(arg) (arg | 0x00)

/* Master Reset */
/* Reset CNTR, ICR, OCCR, QR, BWT, CYT, OL, COMPT, and PR/OL Byte Pointer */
/* Set PR and SIGN */
#define Rst_Master 0x20

/* Reset COMPT */
#define Rst_COMPT 0x10

/* Transfer PR to CNTR (24 bits) */
#define Trf_PR_CNTR 0x08

/* Reset CNTR, BWT and CYT */
/* Set SIGN bit */
#define Rst_CNTR_BWT_CYT_Set_SIGN 0x04

/* Transfer CNTR to OL (24 bits) */
#define Trf_CNTR_OL 0x02

/* Reset PR/OL Byte Pointer */
#define Rst_BP 0x01

/*****/
/* ICR (Input Control Register) */

/* Select ICR */
#define ICR(arg) (arg | 0x40)

/* Select  $\overline{\text{LCTR}}$  /  $\overline{\text{LLTC}}$  as Load-CNTR Input */
#define LCNTR 0x00

/* Select  $\overline{\text{LCTR}}$  /  $\overline{\text{LLTC}}$  as Load-OL Input */
#define LOL 0x20

/* Select  $\overline{\text{ABGT}}$  /  $\overline{\text{RCTR}}$  as Reset-CNTR Input */
#define RCNTR 0x00

/* Select  $\overline{\text{ABGT}}$  /  $\overline{\text{RCTR}}$  as Enable / Disable Gate for A / B Inputs */
#define ABGate 0x10

/* Disable A / B Inputs */
#define DisAB 0x00

/* Enable A / B Inputs */
#define EnAB 0x08

```

```

/* Decrement CNTR once for A / B = 1, if A / B inputs are enabled */
#define Decr_CNTR    0x04

/* Increment CNTR once for A / B = 1, if A / B inputs are enabled */
#define Incr_CNTR    0x02

/* Set Input A = Up Count Input, Input B = Down Count Input */
#define AUP_BDN     0x00

/* Set Input A = Count Input, Input B = Count Direction Input */

/* B = 0 selects Up Count Mode */
/* B = 1 selects Down Count Mode */
#define AIN_BDIR    0x01

/*****/
/* OCCR (Output Control Register) */

/* Select OCCR */
#define OCCR(arg)  (arg | 0x80)

/* Set  $\overline{CY}$  =  $\overline{COMP}$  Comparator Out (active "0") */

/* Set  $\overline{BW}$  =  $\overline{COMPT}$  Comparator Toggle Output */
#define COMPN_COMPT 0x30

/* Set  $\overline{CY}$  =  $\overline{CY}$  */

/* Set  $\overline{BW}$  =  $\overline{BW}$  */
#define CY_BW      0x20

/* Set  $\overline{CY}$  =  $\overline{CY}$  */

/* Set  $\overline{BW}$  =  $\overline{BW}$  */
#define CYN_BWN    0x00

/* Set Binary or BCD Count Mode */
#define Bin_BCD_Cnt 0x00

/* Set 24 Hr Clock Mode – Overrides BCD / Binary Modes */
#define Clk_24HR_Cnt 0x08

/* Set Normal Count Mode */
#define Nrml_Cnt    0x00

/* Set Divide by N Count Mode */
#define div_N_Cnt  0x04

/* Set Non Recycle Count Mode */
#define Nrcyc_Cnt  0x02

/* Set Binary Count Mode */
#define Bin_Cnt     0x00

/* Set BCD Count Mode */
#define BCD_Cnt    0x01

/*****/

```

```

/* QR (Quadrature Register) */

/* Select QR */
#define QR(arg) (arg | 0xC0)

/* Enable x4 Quadrature Mode */
#define En_x4QM 0x03

/* Enable x2 Quadrature Mode */
#define En_x2QM 0x02

/* Enable x1 Quadrature Mode */
#define En_x1QM 0x01

/* Disable Quadrature Mode */
#define Dis_QM 0x00

/*****/
/* Initialize 7166 */

void Init_7166(int Addr)

/* Initialize 7166 as follows
Do a Master Reset
Set ICR as follows
Set Input A = Up Count
Set Input B = Down Count
Disable Inputs A/B
Enable Reset_CNTR input
Enable Load_CNTR input
Set OCCR – Normal Count Mode
Disable QM
Enable A and B Inputs
*/

void Init_7166(int Addr){
/* Master Reset */
outp(CTRLMODE(Addr), MCR(Rst_Master));

/* Set ICR */
outp(CTRLMODE(Addr), ICR(AUP_BDN + DisAB + RCNTR + LCNTR));

/* Set OCCR */
outp(CTRLMODE(Addr), OCCR(Nrml_Cnt));

/* Set QR */
outp(CTRLMODE(Addr), QR( Dis_QM));

/*Enable A and B inputs */
outp(CTRLMODE(Addr), ICR(EnAB));
}

```

```
/* Write data into 7166 Preset Register  
Addr has address of 7166 counter  
Data has 24 bit data to be written to PR register */
```

```
void Write_7166_PR(int Addr, unsigned long Data);
```

```
void Write_7166_PR(int Addr, unsigned long Data){  
  outp(CTRLMODE(Addr), MCR(Rst_BP));  
  outp(DATAMODE(Addr), (unsigned char)Data);  
  Data >>= 8;  
  outp(DATAMODE(Addr), (unsigned char)Data);  
  Data >>= 8;  
  outp(DATAMODE(Addr), (unsigned char)Data);  
}
```

```
/* Read 7166 Output Latch  
Addr has address of 7166 counter  
Data returns 24 bit OL register value. */
```

```
unsigned long Read_7166_OL(int Addr);
```

```
unsigned long Read_7166_OL(int Addr){  
  unsigned long Data = 0;  
  outp(CTRLMODE(Addr), MCR(Rst_BP + Trf_CNTR_OL));  
  Data |= (unsigned long) inp(DATAMODE(Addr));  
  lrotr(Data,8);  
  Data |= (unsigned long) inp(DATAMODE(Addr));  
  lrotr(Data,8);  
  Data |= (unsigned long) inp(DATAMODE(Addr));  
  lrotr(Data,16);  
  return(Data);  
}
```

```
/* Read Output Status Register  
Addr has address of 7166 counter  
returns OSR data */
```

```
unsigned long Read_7166_OSR(int Addr);
```

```
unsigned long Read_7166_OSR(int Addr){  
  return(inp(CNTRLMODE(Addr)));  
}
```